

Development of High Frequency Link Direct DC to AC Converters for Solid Oxide Fuel Cells (SOFC)

Dr. Prasad Enjeti

**Power Electronics Laboratory
Department of Electrical Engineering
Texas A&M University
College Station, TX - 77843**

SECA Industrial Partner: Delphi-Auto



Fuel Cell Based Power Generating System

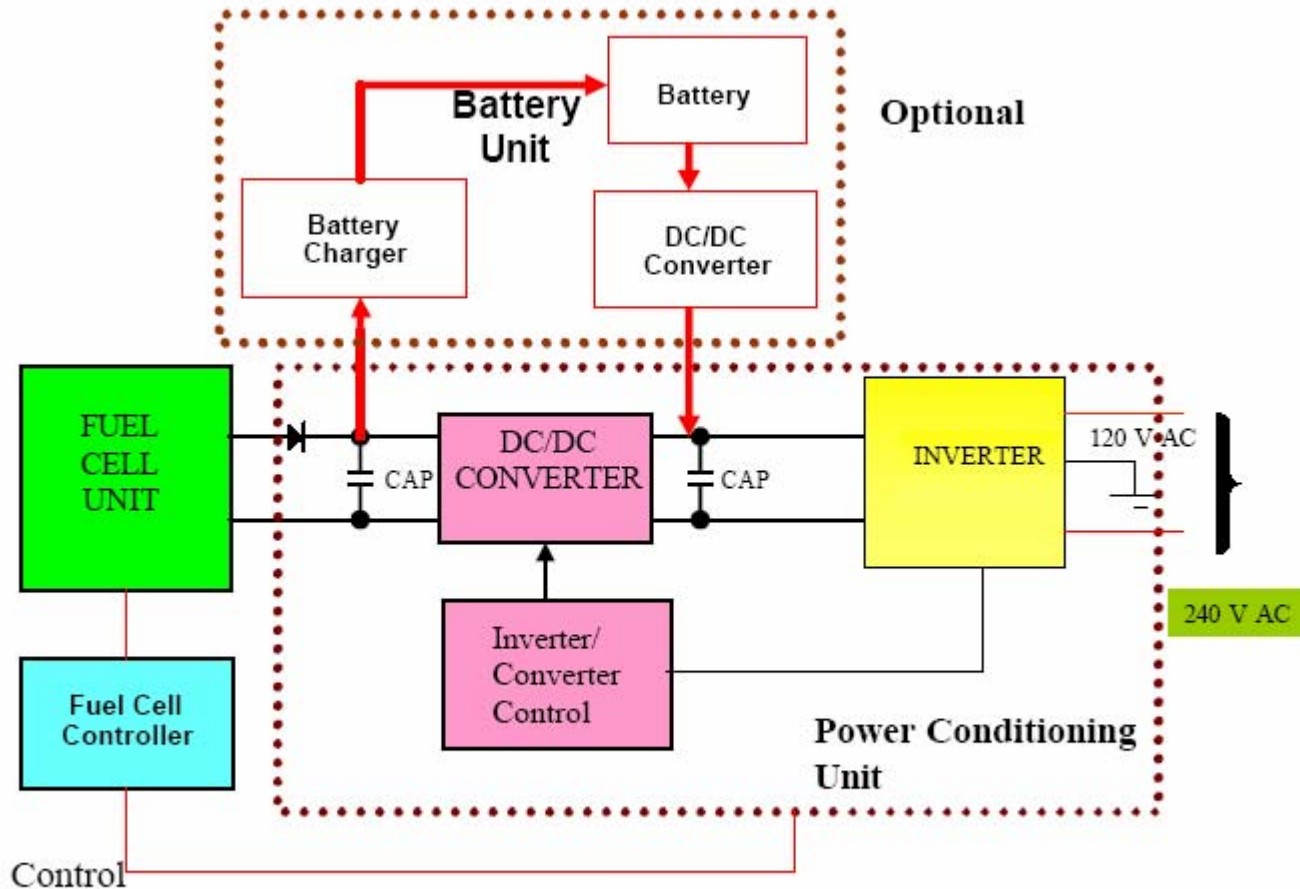

Fig. 1 Fuel Cell Based Stationary Power Generation System (5 KVA)



Modes of Operation

Mode 1 - Grid independent mode or Stand-alone mode. Grid independent or stand-alone mode is used in remote applications or in stand-alone systems to be operated independent of the grid. The battery unit is required to start the fuel cell system operation and to provide the power for the accessories till the fuel cell unit becomes capable of supplying the full power.

Mode 2 – Grid parallel mode. In the grid parallel mode, the fuel cell system will be supplying the power to the base loads and at the same time feed the excess power to the grid. When the grid fails, fuel cell will continue to power the base loads, but it will be completely disconnected from the grid. In this mode, there is no need for the battery unit. The fuel cell can be started using the power from the grid.

Mode 3 – Grid only Operation. In this mode, the fuel cell system will be feeding all the generated power to the grid. In this mode also, there is no need for a battery. The fuel cell can be started using the power from the grid.

Mode 4 - Back-up power in UPS applications. In this mode, the loads are powered by the grid power. When the grid fails, the battery powers the base loads and also provides the power for starting the fuel cell



High Frequency Link Direct DC to AC Converters for SOFC

- ◆ This project proposes to design and develop high frequency link direct DC to AC converters to improve performance, optimize the size, cost, weight and volume of the DC to AC converter in SOFC systems
- ◆ The proposed topologies employ a high frequency link, direct DC to AC conversion approach. The direct DC to AC conversion approach operates without an intermediate dc-link stage
- ◆ The converter concept could result in lower weight/volume/size and cost of the power generating system



Fuel Cell Power Conditioning Stage: Block diagram: Direct DC to AC

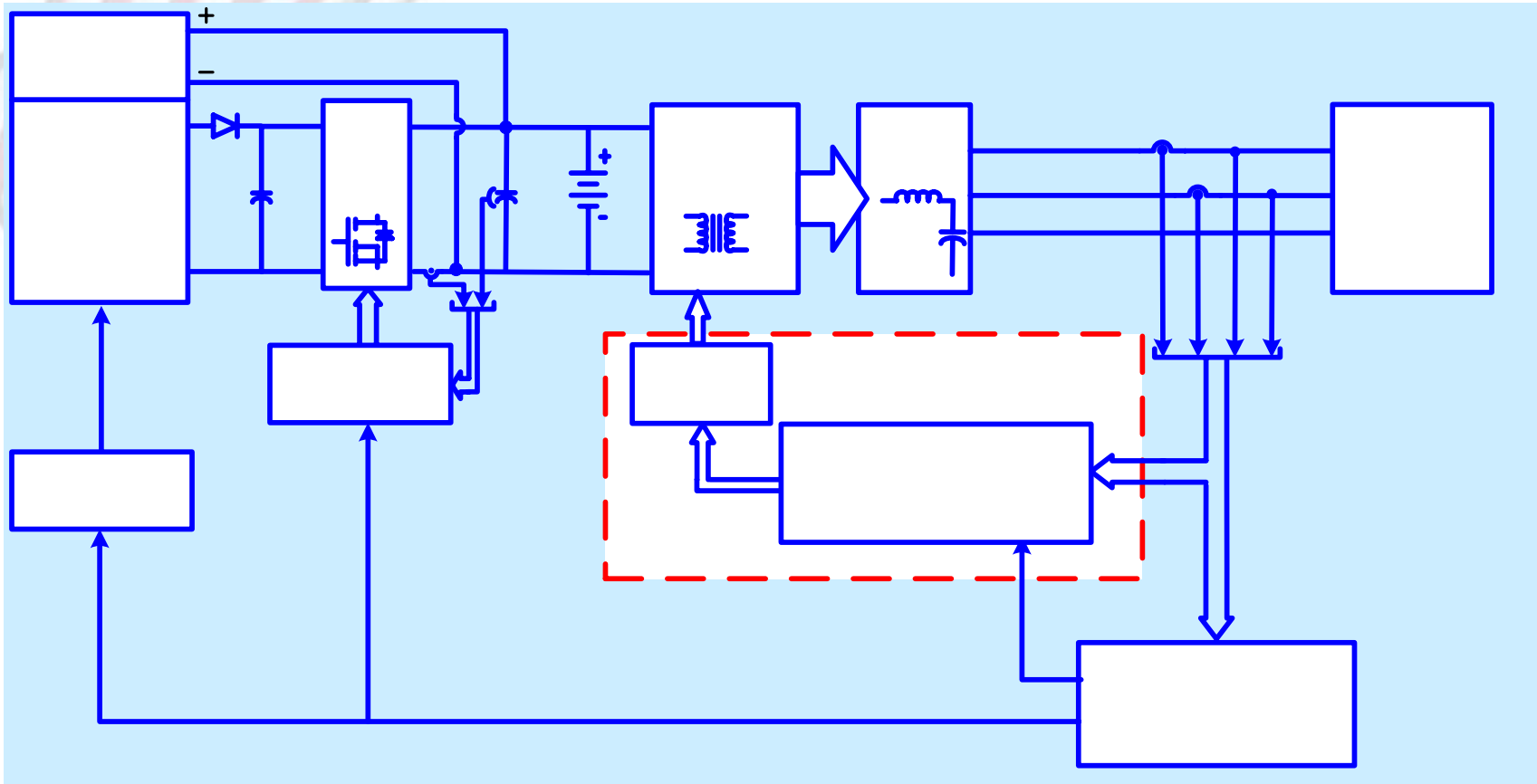

ACCESSORY LOADS





R&D Objectives & Approach

- ✚ The primary objective is to realize cost effective fuel cell converter, which operates under a wide input voltage range, and output load swings with high efficiency and improved reliability
- ✚ Employ state of the art power electronic devices & configure two unique topologies to achieve direct conversion of DC power (36-60V) available from a SOFC to AC power (120/240V, 60Hz) suitable for utility interface and powering stand alone loads
- ✚ Investigate direct DC to AC conversion



Project Status

- **Evaluated three direct DC to AC converter possibilities for SOFC systems**
- **Reduced switch voltage/current fed direct DC to AC system**
- **Voltage source direct DC to AC system with and without battery**



Converter Specifications

- Input voltage varies from 36 V to 60 V DC
- Output Voltage: 120/240 V, 50 or 60 Hz Single Phase , 3 wire + ground
- The output power of the PCU is: 5 kW (1.0 PF)
- The Target efficiency is 90% minimum at rated power, 83% minimum at 2.5 kW.
- Maximum housekeeping power with no load is 50 W
- Max 5% RMS current ripple at 120 Hz on the fuel cell DC bus



Reduced Switch Voltage-fed High Frequency Link Direct DC to AC Converters for SOFC

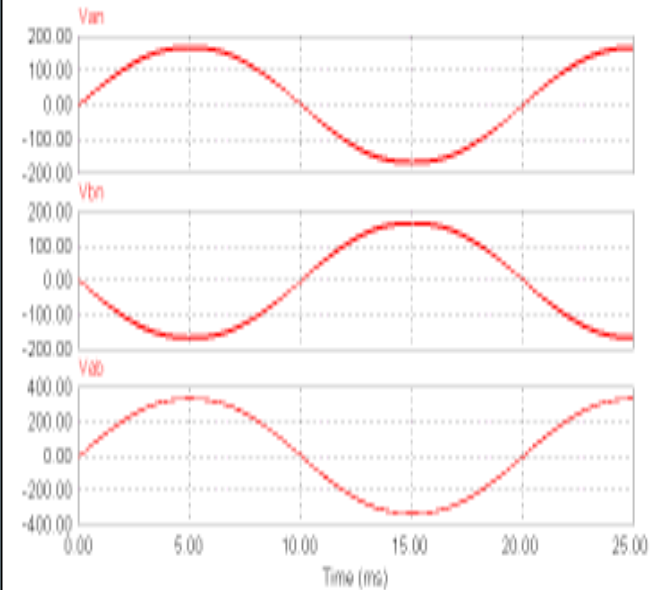
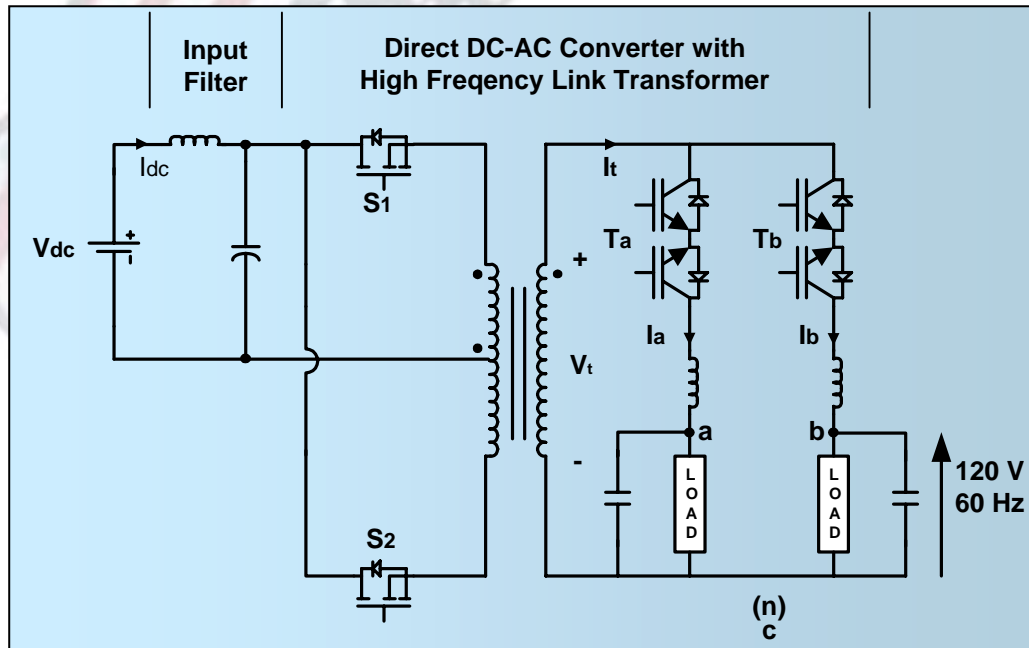

- ✚ Direct DC to AC power conversion of fuel cell voltage (36V) to 120/240V AC, 60Hz
- ✚ The switches are operated in high frequency (40kHz), zero current switching (ZCS) mode
- ✚ Not suitable for > 1kW rating due to high peak currents and discontinuous current conduction.



Voltage source type direct DC to AC Power Conditioning Unit (PCU) without a Battery

SOFC Fuel Cell
(36V to 60V)

Input L-C Filter

Direct DC to AC Converter

120V/240V
1-phase, 3-wire
Output

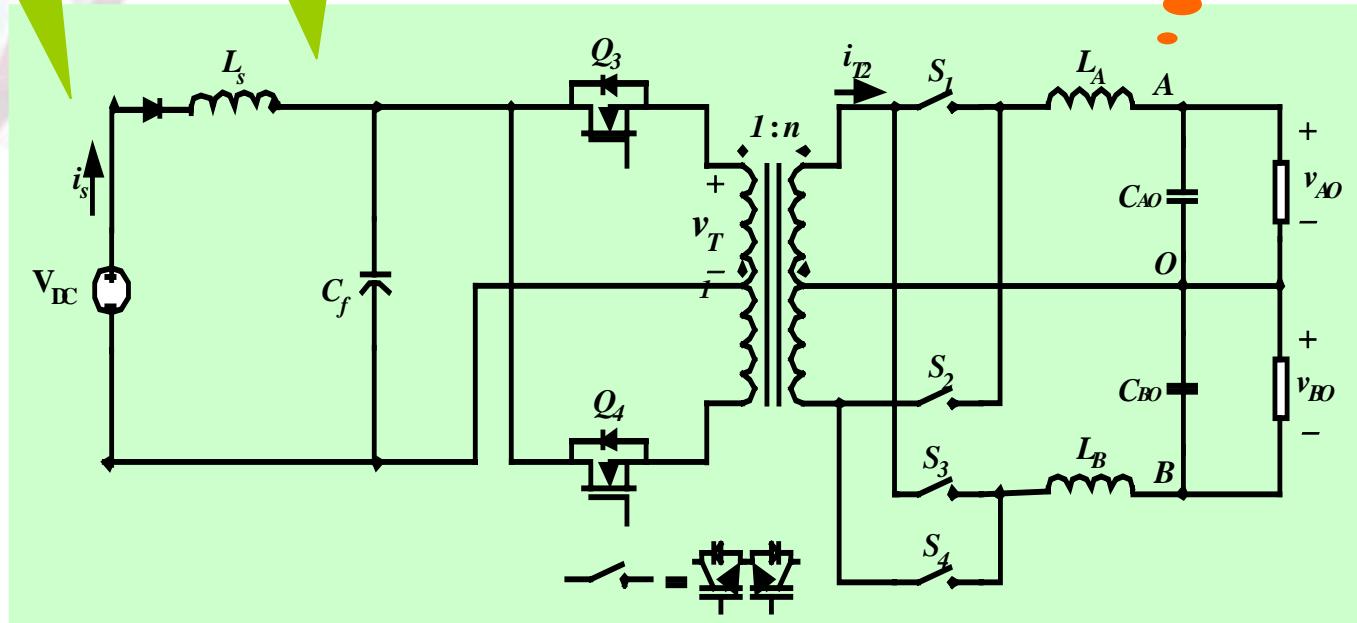

Voltage source type direct DC to AC Power Conditioning Unit (PCU) with a Battery

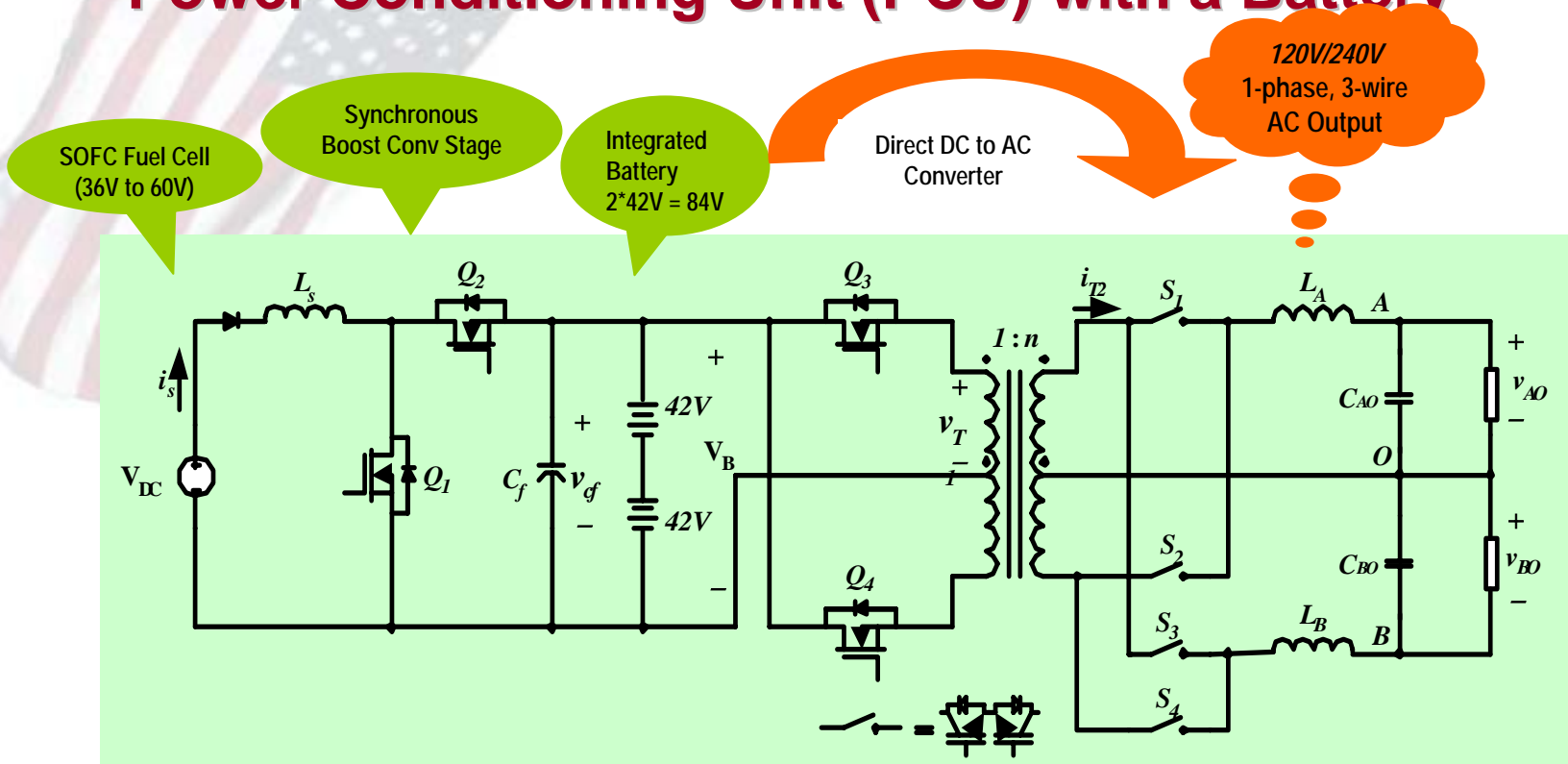

- With the synchronous boost stage the direct dc to ac design can be optimized to maximize performance and efficiency
- Hardware implementation of this scheme is in progress



Results

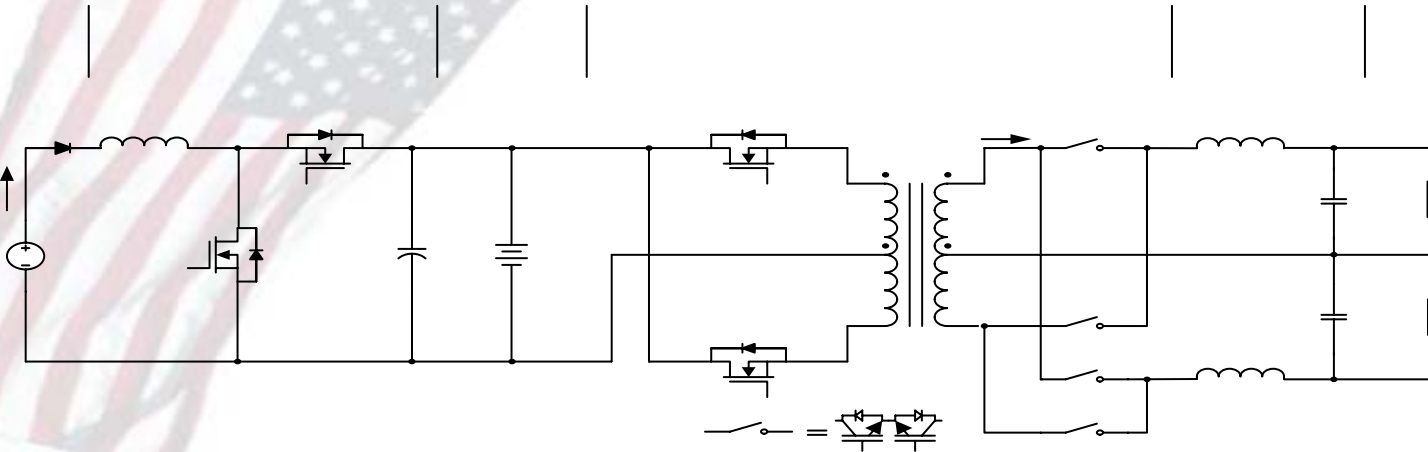

$P_o = 3 \text{ kVA}$, $V_{AO,rms} = 120 \text{ V}_{rms}$, $I_{AO,rms} = 12.5 \text{ A}_{rms}$, $f_s = 20 \text{ kHz}$, $f_{boost} = 100 \text{ kHz}$,
 $f_{dc-ac} = 20 \text{ kHz}$

Fuel

erter

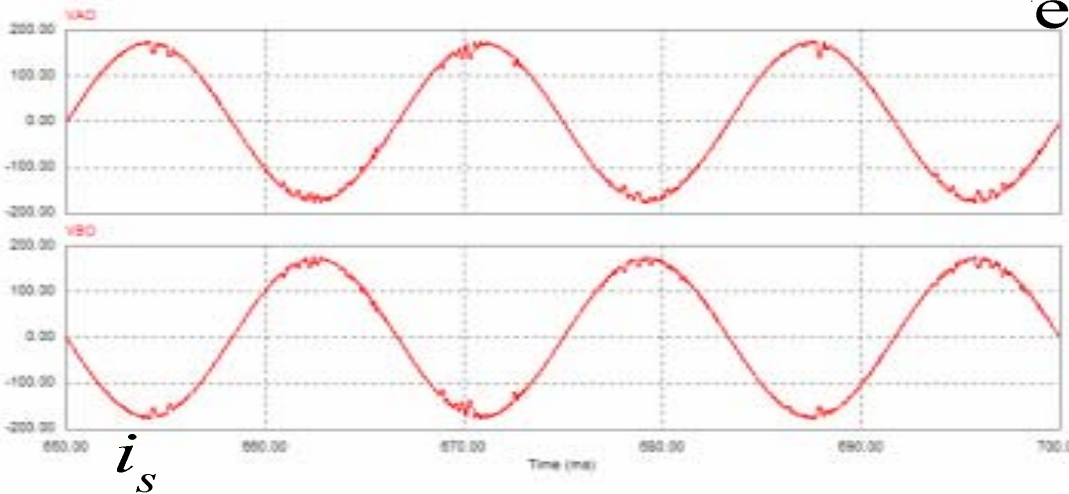

Q_2



Results

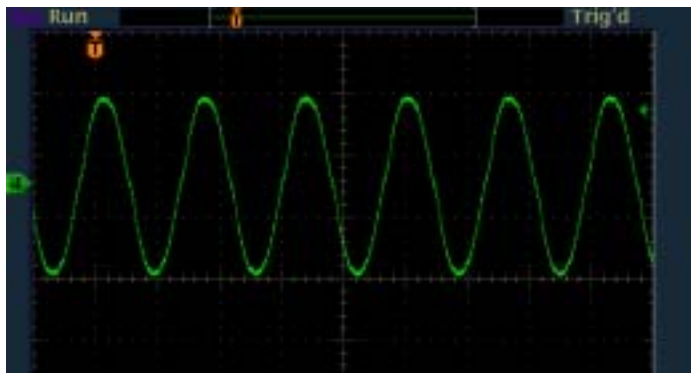
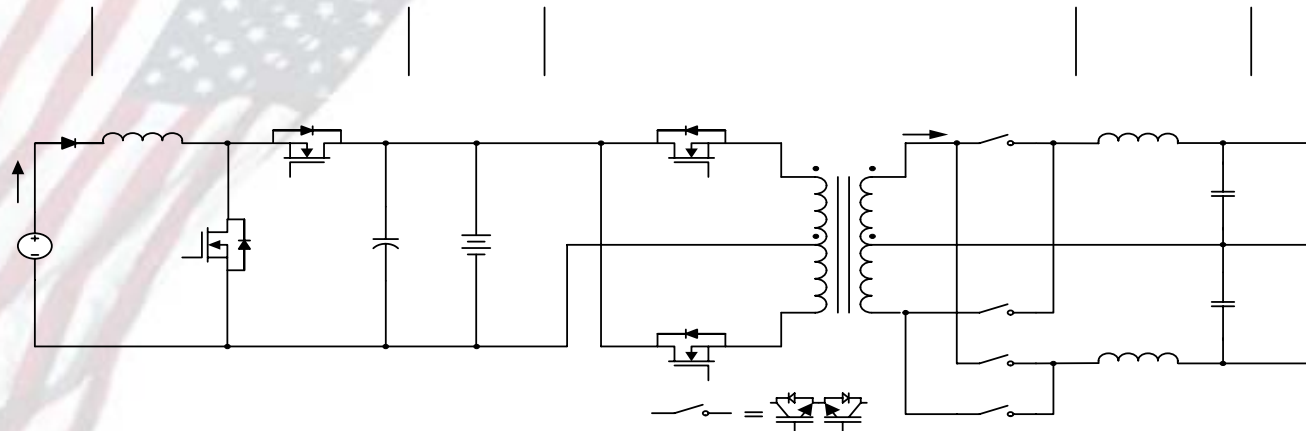

F
C



erter

Q_2

i_s



Results

- Transformer Overheating occurred at rated load**
- Transformer re-design is in progress**
- Modifications to four step switching strategy is underway to reduce over voltage on switches**
- Integration of the boost stage and the battery will be conducted in Phase-II**

