

# TECHBRIEF

## FIBER OPTIC PH SENSOR FOR HIGH-TEMPERATURE AND HIGH-PRESSURE ENVIRONMENTS

### OPPORTUNITY:

This invention describes a pH sensor comprising an optical fiber coated with metal-oxide based pH sensing materials for use in high-temperature and high-pressure environments such as wellbores and the challenging high pH range relevant for wellbore cement. This technology is available for licensing and/or further collaborative research from the U.S. Department of Energy's National Energy Technology Laboratory.

### CHALLENGE:

Various fossil energy and carbon management applications require chemical composition monitoring in subsurface environments. Examples of these areas include deep and ultra-deep oil and gas resource recovery through drilling and hydraulic fracturing techniques as well as environmental monitoring in reservoirs for carbon dioxide (CO<sub>2</sub>) sequestration. Accurate measurement of pH in subsurface wellbores is critical for early corrosion detection and wellbore cement failure prediction.

However, these subsurface environments are extremely challenging for the development and deployment of sensing technologies because of harsh conditions such as high temperatures, high pressures, corrosive chemical species, and potentially high salinity. In such harsh environments, most electrical and electronic components used in sensor applications are not feasible. Additionally, real-time monitoring of pH within cement is challenging because the high-pH range (pH ~13) can cause stability issues of commonly used pH sensing materials at high temperatures. Therefore, it is essential to develop approaches that provide stable pH sensing and that could eliminate the use of electrical components and connections at the sensing locations and avoid the common mode of failure in conventional sensors.

### OVERVIEW:

This invention proposes metal oxide (MeOx)-based optical pH sensitive materials and optical fiber sensors employed for high-pH and high-temperature subsurface conditions. Compared to traditional sensing methods, fiber-optic pH sensors offer several advantages. Fiber optic sensors can avoid using electrical components and wiring, and they are immune to electromagnetic interference. In addition, they do not need a separate reference electrode as required in potentiometric sensing methods, which leads to stability issues at high temperature applications.

More importantly, they can be used for remote, distributed and continuous pH sensing in harsh environments. Fiber optic sensors have been

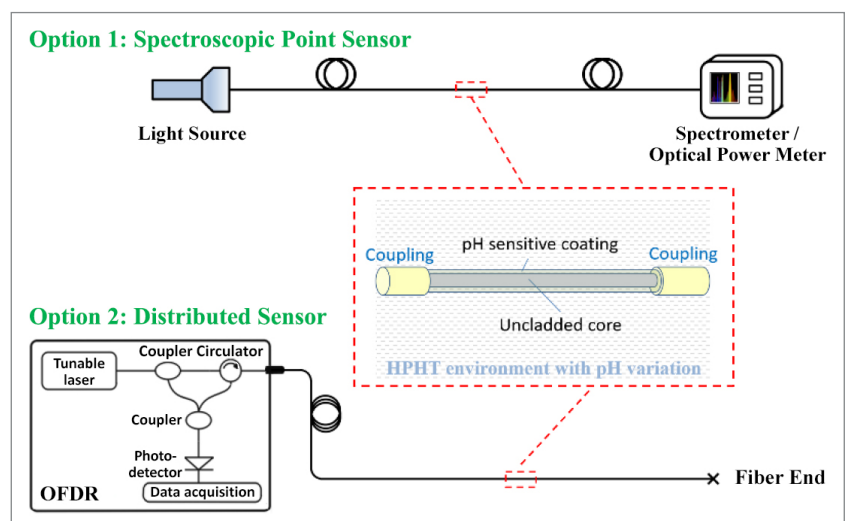

(continued)



**FOR MORE INFORMATION:**

Agreements:  
TTAgreements@NETL.DOE.gov

Licensing:  
TTLicensing@NETL.DOE.gov

Customer Service:  
**1.800.553.7681**

626 Cochran Mill Road  
Pittsburgh, PA 15236  
412.386.4984 (receptionist)

3610 Collins Ferry Road  
Morgantown, WV 26505  
304.285.4764 (receptionist)

1450 Queen Avenue SW  
Albany, OR 97321  
541.967.5892 (receptionist)

deployed for distributed temperature and pressure sensing in the subsurface, for example, utilizing fiber-Bragg gratings on the optical fiber or backscattered light interrogation. However, fiber optic chemical sensors, such as pH sensors, have not yet been commercially available due to the lack of useful, reversible and robust sensing materials that can perform in demanding conditions in the subsurface. The invention described here directly addresses this need by demonstrating a group of sensing materials, MeOx, that present a good optical response to pH with reversibility and repeatability in the conditions of elevated temperature and pressure and are suitable for deployment in subsurface environments.

**ADVANTAGES:**

- Chemically and thermally stable.
- Lightweight and small-sized.
- Immune to electromagnetic interference.
- Reversible, repeatable and robust sensing materials.
- Compatibility with spectroscopic point sensors and distributed long-distance sensing.
- Multi-parameter monitoring when combined with other sensing materials.
- Suitable for embedded sensing in subsurface conditions.

**APPLICATIONS:**

- Real-time pH monitoring in:
  - o Downhole conditions for early corrosion detection and cement failure prediction of the wellbore components (e.g. casing steel and cement).
  - o Aqueous geological formation conditions relevant for CO<sub>2</sub> sequestration.
  - o Wellbore plugs of abandoned wells to ensure safe and secure plugging.
  - o Condensed water phase in the natural gas pipeline as an indicator of real-time corrosion monitoring (e.g. top-of-the-line corrosion).
  - o Nuclear power generation applications.
  - o Industrial chemical processes.
- Replacement of standard electrode-based pH meters in common pH sensing experiments due to the broad pH range, rapid response time, and low hysteresis of response, particularly for locations that are difficult to reach.

**PATENT STATUS:**

U.S. Patent Pending (non-provisional patent application)

Filed: 04/26/2022

Title: Metal Oxides Enabled Fiber Optic pH Sensors for High temperature High pH Subsurface Environments

Inventors: Fei Lu, Ruishu Wright, Paul Ohodnicki, Ping Lu

NETL Reference No: 20N-24