

Section 8

AMMONIA BY COAL GASIFICATION PROCESS

T. Sueyama
T. Tsujino
K. Okada

Plant Engineering Division
Ube Industries, Ltd.
7-2, Kasumigaseki
3-chome, Chiyodaku
Tokyo 100, Japan

CONTENTS

ABSTRACT	8-2
HISTORICAL CHANGE OF RAW MATERIALS FOR UBE'S GASIFICATION PLANTS	8-3
TECHNICAL DEVELOPMENTS BY UBE	8-5
Brief History	8-5
Research and Development on TCGP-Associated Technology	8-6
OUTLINE OF AMMONIA PLANT IN UBE AMMONIA	8-9
Process Flow	8-9
Plant Layout	8-14
Plant Performance and Economics	8-14
CURRENT STATUS OF COAL GASIFICATION AND ITS FUTURE	8-16
REFERENCE	8-20
Attachment : Table 1	
Fig. 1 - 5	

ABSTRACT

Ube Industries, Ltd. ("UBE"), which made inroads into the chemical fertilizer industry in 1934 using Ube coal as raw material, has successfully overcome several energy crises over a period of half century.

Recently, in its subsidiary, Ube Ammonia Co., Ltd. ("UBE AMMONIA"), UBE has completed the world's first large-scale ammonia plant based on the Texaco coal gasification process ("TCGP").

Further, in the course of the construction of UBE AMMONIA's new Coal Gasification Plant, UBE has developed a number of its associated technology. It is striking that the new plant was completed and commissioned in an extremely short time using the extensive know-how and experiences accumulated in the construction and operation of Texaco oil gasification plants.

The new coal gasification plant was constructed for the purpose of switching the feedstock from naphtha or LPG to coal in UBE AMMONIA's existing large-scale steam reforming plant.

To reduce the ammonia production cost, not only the new feedstock but also carefully studied plant designs such as optimum utility energy system and coal-water slurry concentration have been taken into consideration.

The production cost has in fact been reduced as expected, and has shown a considerably lower energy consumption in a comparative study of other coal gasification processes.

The results are promising for the future applications such as C1 chemistry, combined-cycle power generation and SNG production.

HISTORICAL CHANGE OF RAW MATERIALS FOR UBE'S GASIFICATION PLANTS

UBE's chemical industries centering around ammonia production started in 1934 with the production of ammonium sulfate from low quality coal from the UBE colliery by the Koppers process.

Then, accompanied with the progress of the energy revolution throughout the 1950's, a switchover from solid raw materials to liquid raw materials became an overriding problem, and in 1960, UBE launched the gasification of crude oil by the Texaco process as shown in Table 1.

Two large-scale ammonia projects followed in the mid-1960s, both based on the naphtha steam reforming process The Sakai Plant (700 ton NH₃/d) and Ube Ammonia Co., Ltd.'s Plant (1,250 ton NH₃/d).

To keep the small-scale gasification plant competitive with the large-scale plants, UBE developed vacuum residue gasification technology foreseeing an inevitable shifting to the so-called "black chemistry" of low-priced vacuum residue from the so-called "white chemistry" of LPG, naphtha, etc.

The development of the "black chemistry" by this small-scale plant finally led in 1982 to the completion of the technology using substantially solid petrocok as a gasification raw material. This gasification technology has played an important role in the detail engineering of the coal gasification process which will follow.

During these five years, making full use of all our resources available, UBE have studied so much on coal gasification processes and economics, and started construction of Ube Ammonia Coal Gasification Plant under the Texaco process to replace its existing steam reforming ammonia plant in June 1983. After the commissioning of the plant in July 1984, UBE succeeded in the continuous production of ammonia from coals in early August, 1984.

Table 1
Changes of Raw Materials for Ammonia in UBE

Process	Raw Material	Plant Capacity (t/d)	Year (A. D.)
UBE Factory			
Koppers	Coal	300	1934 — 1965
Texaco	Crude Oil	420	1960 — 1972
"	Atm. Residue	425	1972 — 1972
"	Vac. Residue	425	1973 — 1979
"	Heavy Fuel Oil	1,000 Nm ³ /h (CO Gas)	1979 — 1982
"	Petrocoke	"	1982 — →
SAKAI Factory			
I.C.I.-Kellogg	Naphtha	700	1967 — 1982
"	LPG/LNG	700	1980 — →
UBE Ammonia			
I.C.I.-Kellogg	Naphtha	1,250	1972 — 1981
"	LPG	1,250	1981 — 1984
Texaco	Coal	1,000	1984 — →

TECHNICAL DEVELOPMENTS BY UBE

Before constructing its TCGP commercial plant, UBE carried out various TCGP technical development works covering a wide range of raw material from conventional crude oil to petrocok, secured necessary know-how at the basic design stage, and advanced smoothly in a relatively short time with detail design, construction, commissioning and final operation of the new coal gasification plant. The history of these developments is outlined below.

Brief History

- 1980 July : Comparative study on each coal gasification process available (F/S)
- Oct. : Selection of Texaco process

- 1981 Jan. - April :
Pilot test at Montebello Research Laboratory (MRL)

- 1981 June - 1982 June :
Research and development on TCGP-associated technology

- 1982 July - Oct. :
Preparation of process design package

- 1982 Nov. : Start of basic design

- 1983 Feb. : Start of detail design

- 1983 May : Start of site work

- 1984 June : Mechanical completion

- 1984 July : Commissioning

- 1984 Aug. : Commercial operation

Research and Development on TCGP Associated Technology

Pilot plant gasification tests ;

1981 Jan. - Apr.:

MRL : One kind of U.S. coal
One kind of Canadian coal
One kind of Australian coal

1982 Oct. - 1983 Feb. :

UBE : One kind of Australian coal
One kind of Canadian coal
Two kinds of South African coal

Developments of design and engineering technology for special units related to TCGP;

(a) Grinding and slurry preparation

- 1) Study on physical properties of high concentration coal water slurry
- 2) Research on additives
- 3) Pilot plant test for slurry transportation
- 4) Grinding test by ball mill and rod mill
- 5) Mill screen performance test
- 6) Agitator performance test for slurry tank
- 7) Development of special valve for slurry handling

- (b) Process burner
 - 1) Atomizing test for various types of burner
 - 2) Performance test for various types of burner in UBE petrocoke plant
 - 3) Performance test for several kinds of material in UBE petrocoke plant

- (c) Gasifier operating temperature measurement
 - 1) Performance test for various kinds of protection tubes for thermocouple
 - 2) Development and demonstration of "Syngas temperature estimation program" (STEP) in UBE petrocoke plant
 - 3) Development of optical pyrometer design

- (d) Gasifier refractory
 - 1) Laboratory test for various kinds of domestic and foreign bricks
 - 2) Panel test in operating gasifier

- (e) Gasifier quench chamber
 - 1) Pilot plant test for gas-liquid two-phase flow and its simulation in the quench chamber
 - 2) Optimization of the quench chamber dimensions and application to the petrocoke plant

- (f) Lock hopper
 - 1) Demonstration test for lock hopper valve in the petrocoke plant

(g) Slag treatment

1) Slag screen performance test

2) Char settling test

3) Char filtration test

(h) Waste water treatment

1) Sludge filtration test

(i) Selection of materials

In selecting materials of construction including valves and lining material various tests on corrosion and erosion resistance were carried out.

OUTLINE OF AMMONIA PLANT IN UBE AMMONIA

Process Flow

An outline of process flow is shown in Fig. 1 UBE AMMONIA adopted the new coal gasification process as an alternative "front end" of the existing steam reforming process, retaining the same assembly of the synthesis gas compression and ammonia synthesis facility. The plant thus has a wide range of flexibility in selection of raw material depending on any future energy shift. In other words, this plant can produce ammonia from any of coals, naphtha and LPG as required. Each section is outlined below ;

Air separation unit and compressor

The air separation unit for UBE AMMONIA is a conventional low pressure type, and has the largest capacity in Japan. This unit produces not only gaseous oxygen and nitrogen necessary for gasification and ammonia synthesis, but also high-purity liquid argon, liquid oxygen and liquid nitrogen.

The large centrifugal compressors are installed for gasification and ammonia synthesis.

Grinding and slurry preparation section

A ball mill has been installed for grinding feed coal. The grinding characteristics depend largely on the kind of coal, and three trains of ball mill are installed to obtain a coal water slurry with stabilized properties.

The slurry stored in a slurry tank is pumped continuously into the gasifier, and special care should be taken to prevent fluctuations and to keep the supply stable.

Fig. 1 Block Flow Diagram of TCGP-Ammonia Plant

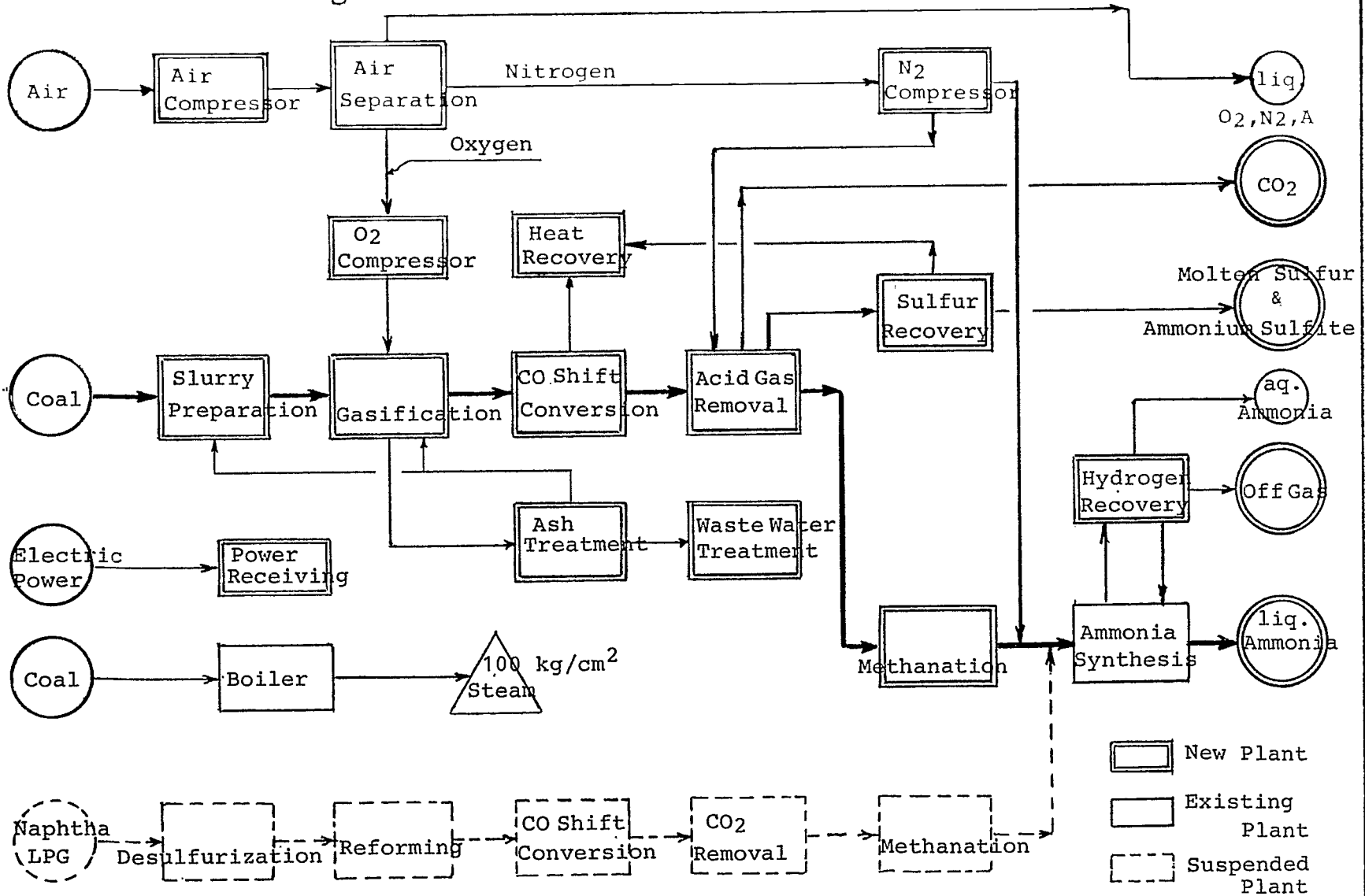

Gasification section

There are four complete trains of quench mode gasifier in this section. In normal operation three trains are used with one for stand-by.

The plant capacity per train is 350 ton NH_3/d .

Some of the individual mechanical features of this section are described below.

(a) Process burner

A burner is mounted on the top of the gasifier, and a coal slurry and oxygen are fed into the gasifier through this burner.

(b) Operating temperature measurement

In the operation of gasifier, the operating temperature measurement system is extremely important.

In oil gasification, a thermocouple has a long life and is highly reliable. However in coal gasification, the molten slag flows on the refractory wall results in a corrosion of a protection tube of thermocouple, thus affecting thermocouple life and reliability. Intensive research and development works have been conducted for the material with longer life protection tube.

(c) Refractory

Since the gasifier operates at high temperature, the pressure shell is protected by three layers of lining bricks.

The hot-face layer is exposed to the most severe condition, not only because it is at high temperature, but also because the molten slag flows down its surface.

As a result of intensive tests on the brick material, UBE has selected a satisfactory brick.

(d) Lock hopper system

The lock hopper is periodically isolated from the gasifier to discharge the accumulated slag in it.

(e) Dust removal from generated gas

The generated gas from the gasifier contains entrained fine "fly ash" comprising unreacted carbon and ash. This fly ash is mostly removed in the quench chamber and others devices, and then the gas is sent to CO shift conversion section.

Ash treatment section

In this section the slag is separated from the slag/water mixture coming from gasification section allowing the separated water to be reused as quench water and process water for the preparation of slurry. Part of the water is blown down to the waste water treatment section. The recovered slag is effectively used as a raw material for cement industry.

Waste water treatment section

Though the waste water from the TCGP contains less harmful substances than that from other processes, several kinds of facilities are used for further treatment to discharge clean water.

CO shift conversion section

In this section additional hydrogen is produced by the following reaction ;

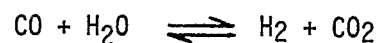

A sulphur tolerant catalyst is used to accomodate sulphurous compounds from the gasification of high sulphur coals.

Surplus heat in the reaction is converted to steam, and electric power is recovered by a generator with this steam.

Acid gas removal section

In this section the Rectisol process is used to remove carbon dioxide and hydrogen sulphide by selective regenerative absorption in low-temperature methanol.

Sulphur recovery section

Sulphur in the hydrogen sulphide fraction from the acid gas removal section is recovered as a molten sulphur by the Claus process.

The ammonium sulphite is also recovered and is effectively used in caprolactam production.

Methanation section

Small amount of carbon monoxide and carbon dioxide remain in the outlet gas from the acid gas removal section. These compounds are catalyst poisons in the ammonia synthesis section so that these are converted to innocuous methane over a catalyst by the following reactions ;

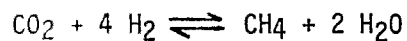
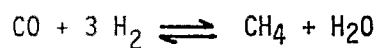

Plant Layout

The plant layout is shown in Fig. 2.

The total plant area is approximately 48,000 m², and the purified synthesis gas from this plant is fed to the existing ammonia synthesis unit which is adjacent the upper boundary on this drawing.

Plant Performance and Economics

So far, the gasification plant has operated using three kinds of coal, Canadian, Australian and South African coal.

Since Canadian coal has a low sulphur content (as low as 0.27%) it was exclusively used in the test run and at each start-up. In normal operation Australian and South African coal are being used for ammonia production.

The overall cost is likely to be reduced by more than 20% by using coal gasification. Furthermore, the coal gasification plant is expected to be more advantageous if the price difference between crude oil and coal continues to increase.

Fig. 2 Layout of Coal Gasification Plant

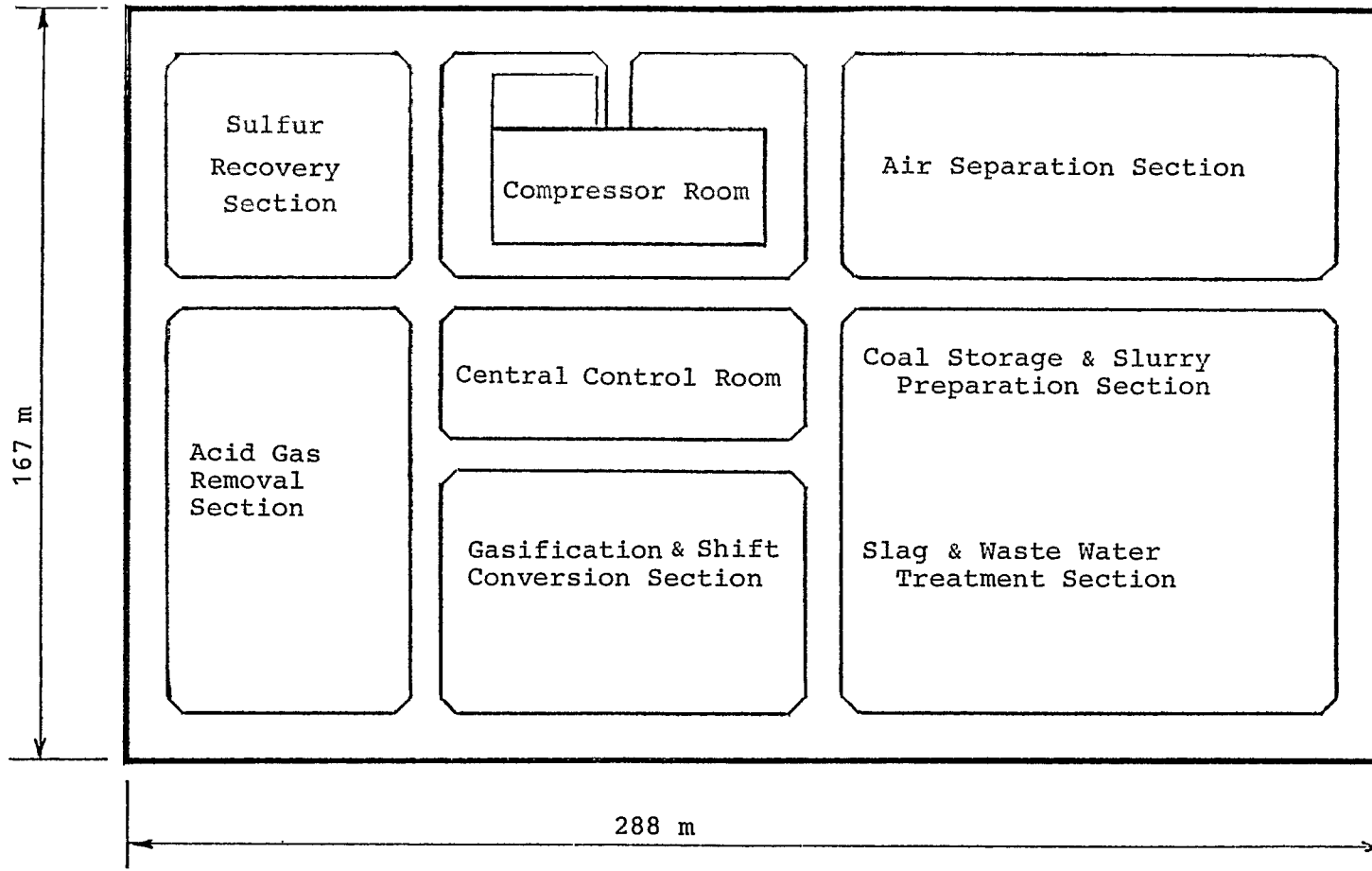

CURRENT STATUS OF COAL GASIFICATION AND ITS FUTURE

Total energy consumption per ton ammonia production is shown in Fig. 3 for various raw materials and processes ¹⁻².

As shown in this figure, steam reforming of natural gas or naphtha is the most advantageous from the point of view of total energy consumption. When the price difference between crude oil and coal was not large, there was no chance to make full use of coal gasification. While steam reforming and partial oxidation of heavy oil are regarded as essentially mature technologies, several processes are still under development for partial oxidation of coal.

As can be seen in Fig. 3, the total energy consumption for ammonia production at UBE AMMONIA shows a better figure of 42 MM BTU/ton NH₃ than the generally quoted figure of 46 MM BTU/ton NH₃. This improved figure implies that the total energy requirement for coal gasification could be far more improved to provide a competitive edge over other processes by further technical developments. In view of its considerable competitiveness and good prospect as mentioned above, coal gasification project should be positively practiced for production of chemical feedstocks.

Fig.4 shows a number of possible applications for chemicals from syngas-based hydrogen and carbon monoxide.

In addition to the production of ammonia from hydrogen and carbon monoxide by coal gasification, UBE is working on developing applications of this feedstock for C1 chemicals as shown in Fig. 5. UBE has already commercialized technologies relating to oxalic acid and oxamide as a slow-release fertilizer for example.

So far, we have commented on the bright outlook for the chemical industry centering around the production of hydrogen and carbon monoxide by the coal gasification process. Furthermore, the produced gas from coal gasification can also be utilized in full applications such as in combined cycle power generation source, town gas or as a raw materials for SNG, etc.

Fig. 3 Energy Requirement for Ammonia

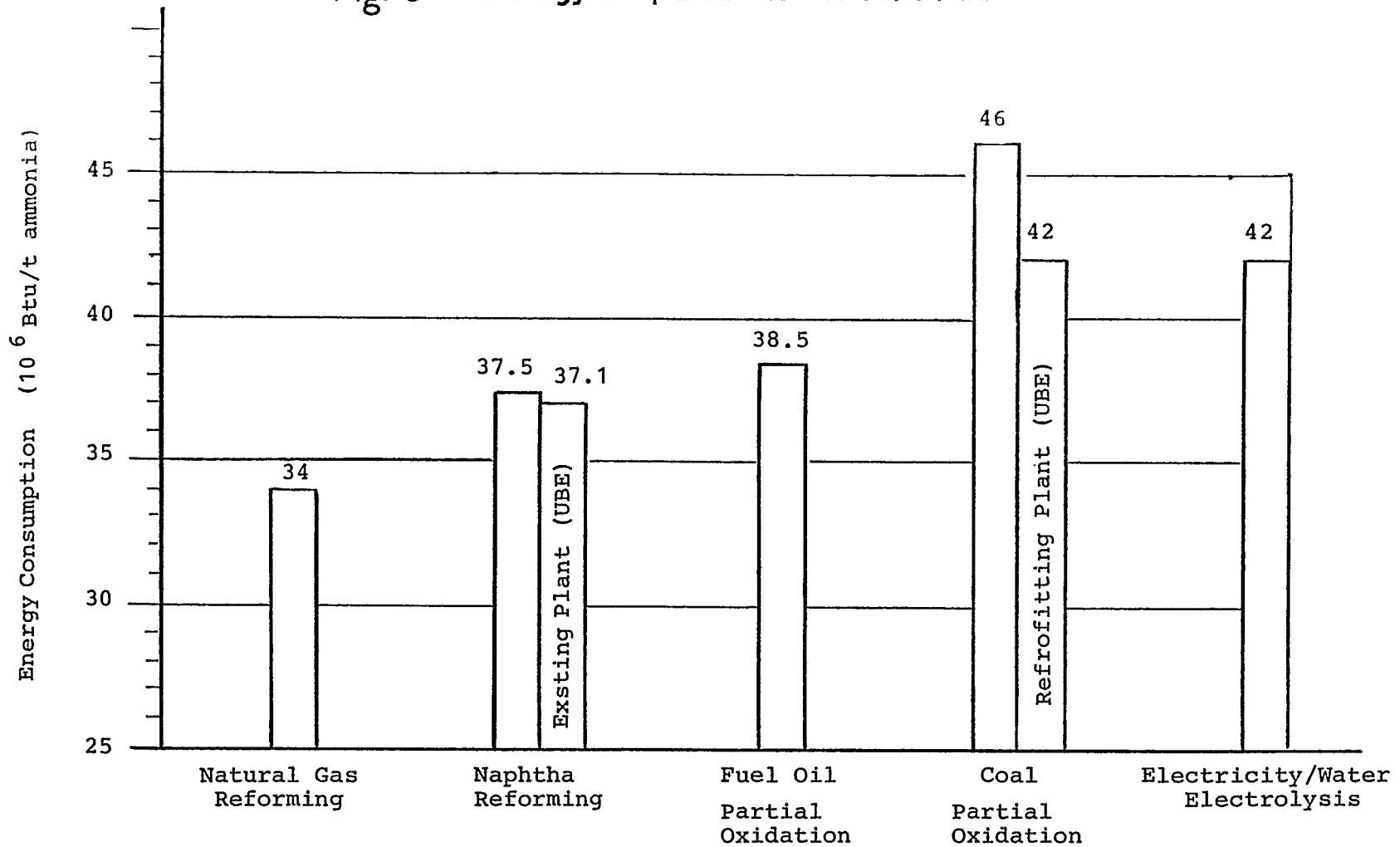

Fig. 4 Chemical Products from Syn Gas

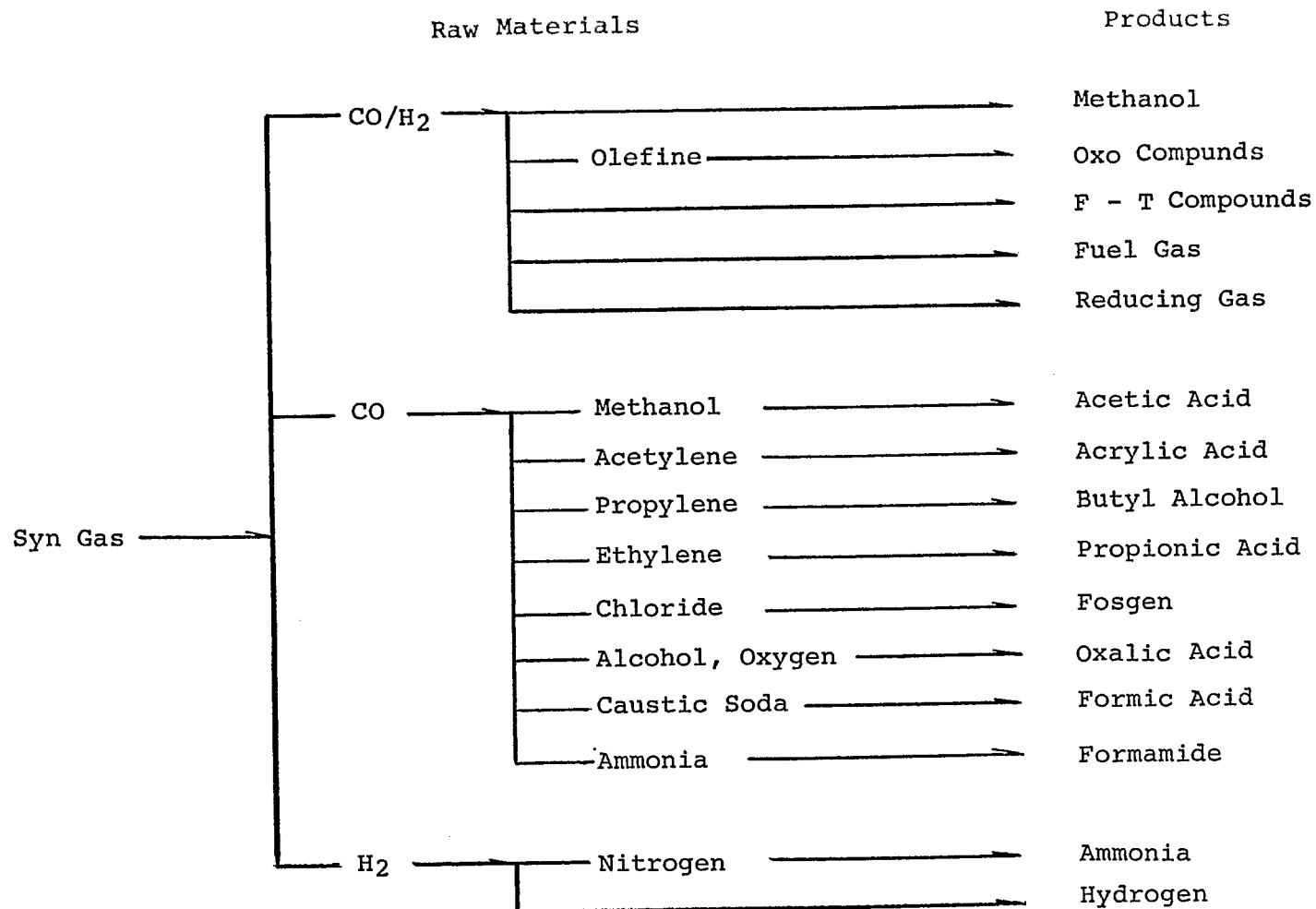
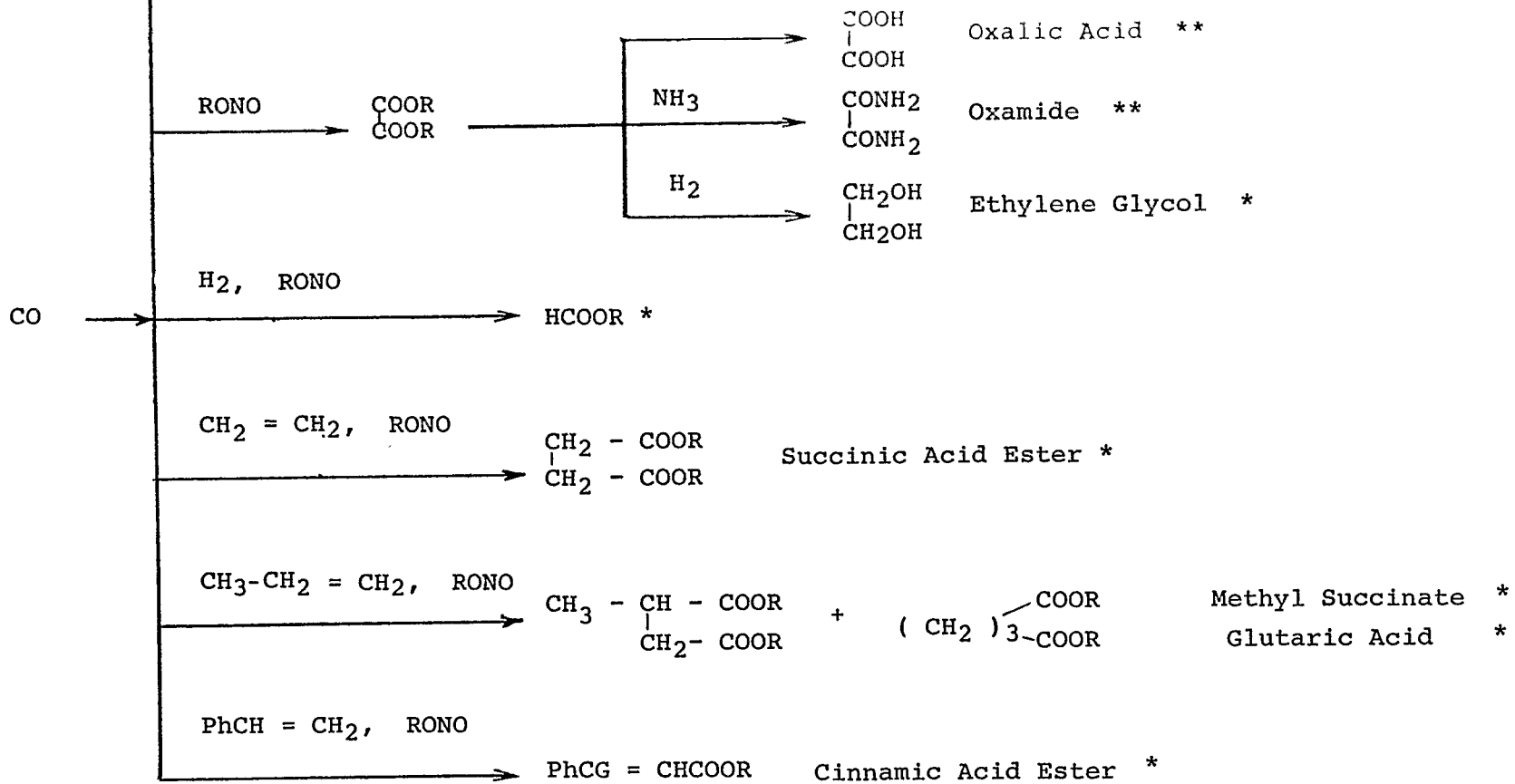

Fig. 5 C 1 Chemistry in UBE

C 1 project

Olefine (Ethylene, Propylene) *

Gas Separating Membrane (Polyimide Resin) **



* Under Developing

** Commercialized

Reference

1. Waitzman D.A., et al. "Fertilizer from Coal"
Presented at the Faculty Institute on Coal Production, Technology and
Utilization
Oak Ridge Associated Universities
Oak Ridge, Tennessee, Jul. 31 - Aug. 11, 1978, 17 - 32
2. Buividas, L.J., Finneran, J.A., and Quartulli, O.J..
"Alternate Ammonia Feedstocks", Chemical Engineering Progress, 21 - 35
(Oct., 1974)

Note

This was prepared by Ube Industries, Ltd. for the purpose of submitting to Electric Power Research Institute (EPRI) for COAL GASIFICATION AND SYNTHETIC FUELS FOR POWER GENERATION CONFERENCE, April 14-19, 1985.

A part of this papers was presented in "International Conference FERTILIZER '85" held in London, 10-13 Feb., 1985 by The British Sulphur Corporation Limited.