

Scale-Up and Testing of Advanced Polaris Membrane CO₂ Capture Technology

primary project goals

Membrane Technology and Research, Inc. (MTR) will design, build, and operate an advanced Polaris™ membrane carbon dioxide (CO₂) capture system at the Technology Centre Mongstad (TCM) using actual flue gas from a refinery catalytic cracker, which simulates coal flue gas. This test system will validate recent membrane technology advancements and mitigate risk in future scale-up activities. The overall MTR membrane process will show the potential to meet the 2030 U.S. Department of Energy (DOE) target of \$30/tonne CO₂ captured from coal-fired power plants. This project will demonstrate a cost-effective advanced membrane process to capture CO₂ from flue gas through slipstream tests at TCM using commercial-scale components. Results from this field test will provide performance data to allow a thorough technical and economic evaluation of the proposed membrane process. Successful completion of this project will signify readiness to proceed to the next step – testing a larger proof-of-concept advanced membrane system on the scale of 10 to 25 megawatts-electric (MWe).

technical goals

- Design the membrane test system and complete host site preparations.
- Fabricate commercial-scale membranes and low-pressure-drop membrane modules.
- Fabricate membrane test system skid, with membrane modules incorporated into skid, and install system at TCM.
- Conduct a minimum six-month field test, including three months of steady-state operation and parametric tests that focus on verifying system performance at partial capture rates that minimize capture costs.
- Evaluate optimal integration of advanced compression into the membrane capture process, including cost estimates.
- Complete a techno-economic analysis (TEA) and environmental, health, and safety (EH&S) assessment of the membrane capture technology.

technical content

In this project, no additional membrane development is required. A previously validated second-generation (Gen-2) membrane will be scaled-up to commercial manufacturing equipment. It is expected that this production scale-up process will produce cost savings through bulk materials usage and application of automated manufacturing equipment.

The goal of this project is to scale-up advanced Polaris Gen-2 membranes and modules to a final form optimized for commercial use, and to validate their

technology maturity:

Engineering-Scale, Actual Flue Gas (equivalent to 1 MWe)

project focus:

Polymeric Membranes

participant:

Membrane Technology and Research, Inc.

project number:

FE0031591

predecessor projects:

FE0005795

FE0026414

NETL project manager:

Isaac Aurelio

isaac.aurelio@netl.doe.gov

principal investigator:

Tim Merkel

Membrane Technology and Research, Inc.

tim.merkel@mtrinc.com

partners:

Technology Centre Mongstad, Dresser-Rand, Trimeric Corporation, WorleyParsons/Advisian

start date:

08.01.2018

percent complete:

39%

transformational potential in an engineering-scale field test at TCM. This program will expand on work conducted by MTR over the past decade with DOE support to develop efficient membrane CO₂ capture technology. This effort has produced the MTR Polaris class of membranes and a patented selective recycle process design that lowers the cost of capture.

Over the course of this development effort, key improvements made were higher-permeance membranes, low-pressure-drop modules, and a process design that optimizes the efficiency of capture.

The Gen-2 Polaris membranes have demonstrated double the CO₂ removal capacity of the original membrane in bench-scale tests at the National Carbon Capture Center (NCCC) (Figure 1). They will be packaged into new modules designed for low-pressure flue gas treatment. Prototypes of these modules have been validated in prior field trials that confirm large energy and cost savings. Assemblies of these modules will be fitted into a standard container that represents the final form factor for this technology, with future commercial systems simply utilizing large numbers of this modular repeat unit.

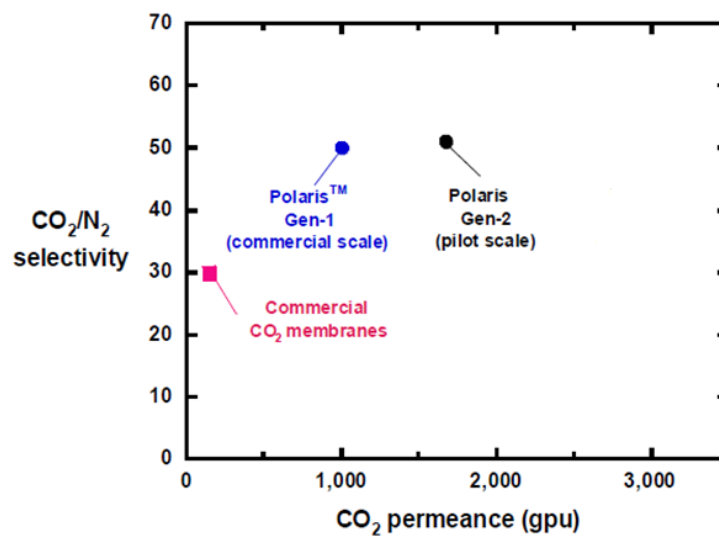

Figure 1: A CO₂/N₂ trade-off plot showing data for two generations of MTR Polaris membrane. Data are pure-gas values at room temperature.

These step-change material and device advances will be incorporated into a system design that takes advantage of the inherent efficiency of membranes for bulk separations. Capture costs can be minimized by operating at partial capture rates (50 to 75%), while still reducing coal plant CO₂ emissions to that of a gas-fired power plant or less. Finally, the pairing of Polaris Gen-2 membrane technology with advanced compression technology will be investigated. This technology combination was previously featured in the DOE Pathways Study as an attractive way to reach future cost targets.

In addition to an advanced membrane material, this project will also utilize a new type of low-pressure-drop module. This plate-and-frame module, in addition to its relatively compact size, had about four times lower pressure-drop at the same test conditions as the spiral modules during field testing at NCCC (Figure 2), resulting in large energy savings.

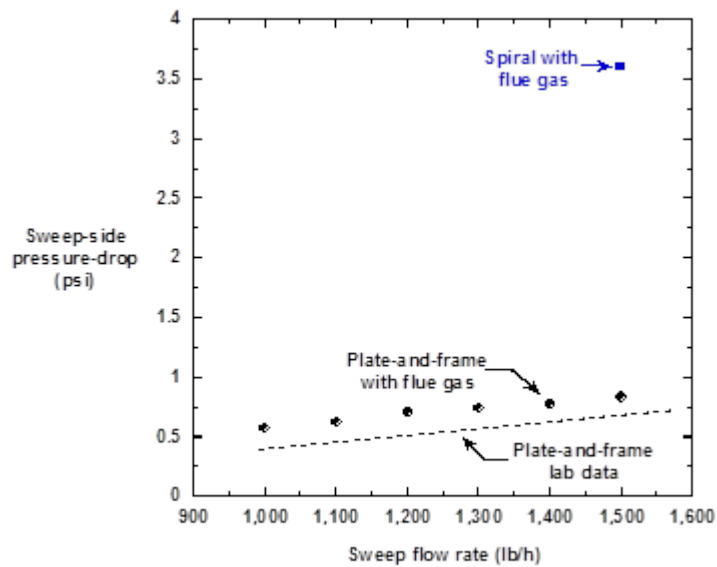

Figure 2: Difference in pressure-drop between spiral and plate-and-frame modules in NCCC field tests.

To reduce the cost of the membrane modules, MTR plans to fabricate them from structural plastics. During this project, a mold flow analysis was completed for the new module design. With this analysis, any issues with the mold design can be identified prior to actual fabrication of the mold and the molding company can determine how to operate their machinery with the MTR mold. Various process parameters were profiled and optimized, including temperature, pressure, number of gates, and gate locations.

Using the mold flow analysis, MTR, along with the domestic mold fabricator and custom plastics injection molding companies, finalized a mold design. A detailed drawing of the new planar stack containing eight membrane modules is shown in Figure 3.

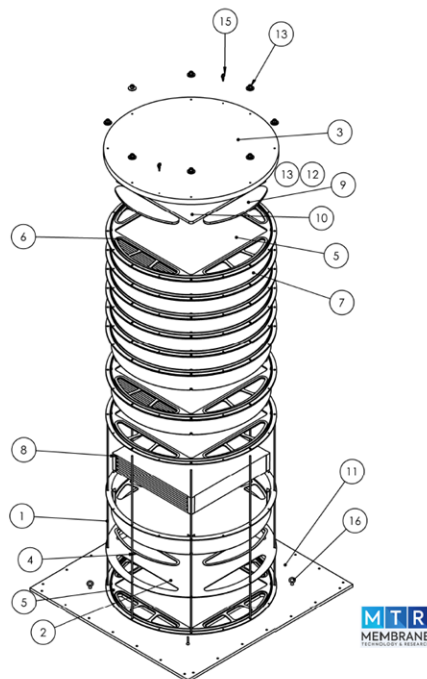

Figure 3: Detailed drawing of a membrane module stack containing eight membrane modules.

Figure 4 shows a simple process flow diagram for the MTR engineering-scale system to be installed at TCM. A slipstream of flue gas is sent to the membrane system (stream 1). After passing through a feed blower, the flue gas (stream 2) goes

to the first membrane skid, where a vacuum on the permeate is used to remove CO₂. The membrane permeate (stream 4) is sent to a second-stage CO₂ purification unit (stream 5). Some of this purified CO₂ can be routed through a spillback line (stream 9) to the front of the membrane system to increase the concentration of CO₂ in the feed from 13 to ~20%. In this way, the feed to the membrane system will mimic the fully integrated case without having to recycle CO₂ to the boiler. With this spillback option, the 20% CO₂ membrane feed contains about 1 MWe worth of CO₂. The partially treated flue gas that leaves the first membrane step (stream 3) is then sent to the sweep membrane unit. Air (stream 6) flows on the permeate-side of these membranes and removes additional CO₂ from the flue gas. The CO₂-enriched air (stream 7) would be sent to the boiler in integrated operation, but here it is just vented after analysis. Finally, the cleaned flue gas (stream 5) flows to the stack.

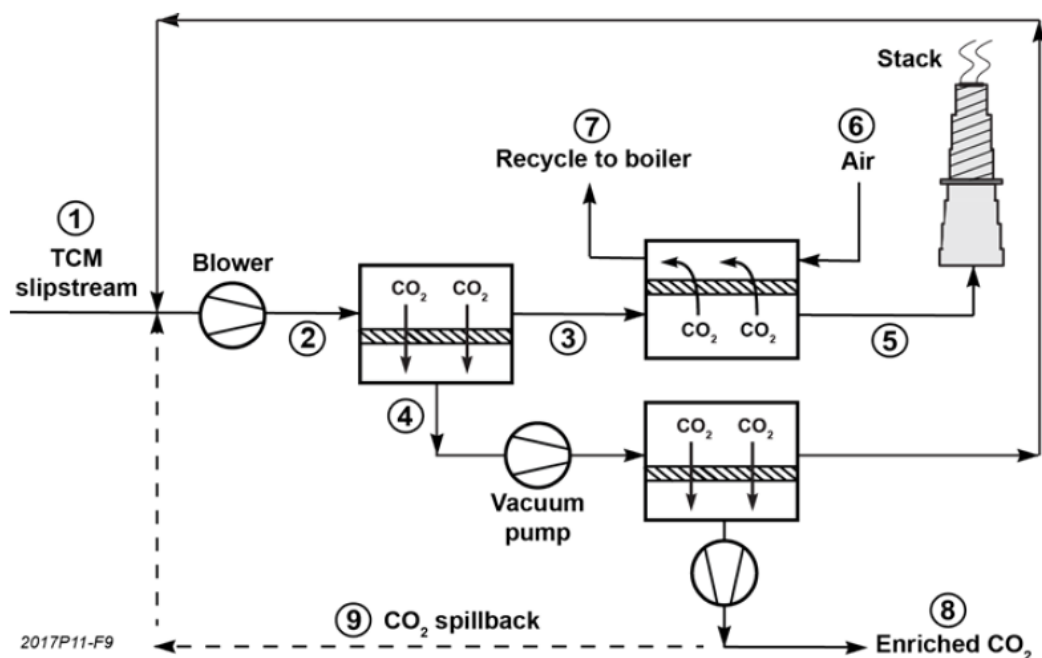

Figure 4: Simplified process flow diagram for the MTR skid operating at TCM.

TABLE 1: MEMBRANE PROCESS PARAMETERS

Materials Properties	Units	Current R&D Value	Target R&D Value
Materials of Fabrication for Selective Layer	—		proprietary polymer
Materials of Fabrication for Support Layer	—		proprietary polymer
Nominal Thickness of Selective Layer	μm	<1	<1
Membrane Geometry	—	flat sheet	flat sheet
Max Trans-Membrane Pressure	bar	70	70
Hours Tested without Significant Degradation	—	>11,000 (real coal)	>13,000 (real and simulated coal)
Manufacturing Cost for Membrane Material	\$/m ²	50	10
Membrane Performance			
Temperature	°C	30	30
CO ₂ Pressure Normalized Flux	GPU or equivalent	1,700	1,700
CO ₂ /H ₂ O Selectivity	—	0.3	0.3
CO ₂ /N ₂ Selectivity	—	50	50
CO ₂ /SO ₂ Selectivity	—	0.5	0.5
Type of Measurement	—	mixed gas	mixed gas

Proposed Module Design*(for equipment developers)*

Flow Arrangement	—	plate-and-frame (crossflow and countercurrent)
Packing Density	m ² /m ³	1,000
Shell-Side Fluid	—	N/A
Flue Gas Flow rate	kg/hr	2,676
CO ₂ Recovery, Purity, and Pressure	%/%/bar	75, >85, 1 (test system conditions)
Pressure Drops Shell/Tube Side	bar	feed: <0.05/sweep: 0.05

Definitions:

Membrane Geometry – Flat discs or sheets, hollow fibers, tubes, etc.

Pressure Normalized Flux – For materials that display a linear dependence of flux on partial pressure differential, this is equivalent to the membrane's permeance.

GPU – Gas permeation unit, which is equivalent to 10⁻⁶ cm³ (1 atmosphere [atm], 0°C)/cm²/s/cm mercury (Hg). For non-linear materials, the dimensional units reported should be based on flux measured in cm³ (1 atm, 0°C)/cm²/s with pressures measured in cm Hg. Note: 1 GPU = 3.3464 × 10⁻⁶ kg mol/m²-s-kPa (SI units).

Type of Measurement – Either mixed or pure gas measurements; target permeance and selectivities should be for mixture of gases found in de-sulfurized flue gas.

Flow Arrangement – Typical gas separation module designs include spiral-wound sheets, hollow-fiber bundles, shell-and-tube, and plate-and-frame, which result in either concurrent, countercurrent, crossflow arrangements, or some complex combination of these.

Packing Density – Ratio of the active surface area of the membrane to the volume of the module.

Shell-Side Fluid – Either the permeate (CO₂-rich) or retentate (flue gas) stream.

Other Parameter Descriptions:

Membrane Permeation Mechanism – Permeation through the Polaris membrane occurs by the passive solution-diffusion mechanism.

Contaminant Resistance – The membranes are known to be unaffected by water (H₂O), oxygen (O₂), and sulfur dioxide (SO₂). The effect of trace contaminants, such as Hg, arsenic, etc., is still under investigation. Polaris modules exposed to coal-fired fuel gas at NCCC for more than a year had no reduction in performance.

Flue Gas Pretreatment Requirements – When placed downstream of existing power plant flue gas emission treatment unit operations to remove particulates (nitrogen oxide [NO_x] and SO₂). The MTR Polaris post-combustion CO₂ capture membrane process design does not require additional pretreatment.

Membrane Replacement Requirements – MTR has installed hundreds of commercial membrane systems in the petrochemical, refinery, and natural gas industries over the past 30 years. The membrane module lifetime is estimated to be three years, which is at the conservative end of the typical industrial gas separation module lifetime of three to five years.

Waste Streams Generated – The MTR capture process will produce a dry, CO₂-depleted flue gas stream routed to the stack and a liquid stream containing much of the moisture in the flue gas (because the MTR membrane captures water as well as CO₂). Prior studies have determined that this water can be recycled to existing flue gas desulfurization (FGD) blowdown wastewater treatment.

technology advantages

- Gen-2 Polaris membranes have a CO₂ permeance approximately twice that of Gen-1 and about 20 times that of conventional membranes.
- There are no hazardous chemicals or emissions in the membrane process.
- The plate-and-frame membrane module minimizes pressure-drop.
- A single-stage system allows for low-cost partial capture, while a novel two-step design efficiently captures CO₂ at high removal rates and high purity.
- The CO₂ recycle increases feed concentration, reducing membrane area and energy requirements.
- High turndown, rapid response to dynamic conditions.
- The membrane module stack reduces module space and cost, which translates into additional cost savings in the system due to reduced ductwork and system complexity.

R&D challenges

- Optimizing CO₂ capture rate to minimize capture cost.
- Long-term stability of Gen-2 membranes.
- High-permeance membrane is required to lower capital cost.
- Pressure-drops must be minimized to reduce energy losses.
- Balance of plant equipment cost/efficiency, particularly for rotating equipment, are critical to system performance.
- Scale-up and integration issues (and operational complications from multiple vacuum pumps and valves, and complicated ductwork in multiple flow banks) likely given the large number of membranes needed to service a 550-MWe plant.

status

A full hazard and operability (HAZOP) review of the MTR test system has been completed with MTR and TCM representatives. The results of the HAZOP were incorporated into the final system design; Progressive Recovery, Inc. of Dupou, Illinois, has been chosen as the fabricator for the MTR test system that will be installed at TCM.

available reports/technical papers/presentations

Merkel, T., et al. "Scale-Up and Testing of Advanced Polaris Membrane CO₂ Capture Technology," presented at the 2019 NETL CO₂ Capture Technology Project Review Meeting, Pittsburgh, PA, August 2019.

<https://netl.doe.gov/sites/default/files/netl-file/T-Merkel-MTR-Advanced-Polaris-Membrane-r1.pdf>

Merkel, T., et al. "Scale-Up and Testing of Advanced Polaris Membrane CO₂ Capture Technology," Project Kickoff Presentation, Pittsburgh, PA, September 2018. [https://www.netl.doe.gov/projects/plp-download.aspx?id=12053&filename=Scale-](https://www.netl.doe.gov/projects/plp-download.aspx?id=12053&filename=Scale-Up%20and%20Testing%20of%20Advanced%20Polaris%20Membrane%20CO2%20Capture%20Technology%20Sept%202018.pdf)

[Up%20and%20Testing%20of%20Advanced%20Polaris%20Membrane%20CO2%20Capture%20Technology%20Sept%202018.pdf](https://www.netl.doe.gov/projects/plp-download.aspx?id=12053&filename=Scale-Up%20and%20Testing%20of%20Advanced%20Polaris%20Membrane%20CO2%20Capture%20Technology%20Sept%202018.pdf).

Merkel, T., et al. "Scale-Up and Testing of Advanced Polaris Membrane CO₂ Capture Technology," presented at the 2018 NETL CO₂ Capture Technology Project Review Meeting, Pittsburgh, PA, August 2018.

[https://www.netl.doe.gov/projects/plp-download.aspx?id=12054&filename=Scale-](https://www.netl.doe.gov/projects/plp-download.aspx?id=12054&filename=Scale-Up%20and%20Testing%20of%20Advanced%20Polaris%20Membrane%20CO2%20Capture%20Technology%20Aug%202018.pdf)

[Up%20and%20Testing%20of%20Advanced%20Polaris%20Membrane%20CO2%20Capture%20Technology%20Aug%202018.pdf](https://www.netl.doe.gov/projects/plp-download.aspx?id=12054&filename=Scale-Up%20and%20Testing%20of%20Advanced%20Polaris%20Membrane%20CO2%20Capture%20Technology%20Aug%202018.pdf).

