



# NETL Life Cycle Inventory Data

## Process Documentation File

**Process Name:** Proton Exchange Membrane, Construction  
**Reference Flow:** 1 piece of PEM, construction  
**Brief Description:** Material inputs associated with the construction of a proton exchange membrane (PEM) electrolysis facility.

### Section I: Meta Data

**Geographical Coverage:** United States      **Region:** N/A  
**Year Data Best Represents:** 2017  
**Process Type:** Installation Process (IP)  
**Process Scope:** Gate-to-Gate Process (GG)  
**Allocation Applied:** No  
**Completeness:** Individual Relevant Flows Recorded  
**Flows Aggregated in Data Set:**  
 Process       Energy Use       Energy P&D       Material P&D

#### Relevant Output Flows Included in Data Set:

Releases to Air:     Greenhouse Gases     Criteria Air Pollutants     Other  
Releases to Water:  Inorganic Emissions     Organic Emissions     Other  
Water Usage:       Water Consumption     Water Demand (throughput)  
Releases to Soil:     Inorganic Releases     Organic Releases     Other

#### Adjustable Process Parameters:

##### stack\_lifetime

*[years] Lifetime of PEM stack.*

##### BOP\_lifetime

*[years] Lifetime of PEM balance of plant (BOP).*

#### Tracked Input Flows:

##### Titanium

*[Technosphere] Titanium input, scaled to reference flow.*

**Stainless Steel**

*[Technosphere] Stainless steel input, scaled to reference flow.*

**Nafion**

*[Technosphere] Nafion (membrane) input, scaled to reference flow.*

**Activated Carbon**

*[Technosphere] Activated carbon input, scaled to reference flow.*

**Iridium**

*[Technosphere] Iridium input, scaled to reference flow.*

**Platinum**

*[Technosphere] Platinum input, scaled to reference flow.*

**Low Alloyed Steel**

*[Technosphere] Low alloyed steel input, scaled to reference flow.*

**High Alloyed Steel**

*[Technosphere] High alloyed steel input, scaled to reference flow.*

**Plastic**

*[Technosphere] Plastic input, scaled to reference flow.*

**Electronic Material**

*[Technosphere] Electronic material input, scaled to reference flow.*

**Adsorbent and Lubricant**

*[Technosphere] Adsorbent and lubricant input, scaled to reference flow.*

**Concrete**

*[Technosphere] Concrete input, scaled to reference flow.*

**Aluminum**

*[Technosphere] Aluminum input, scaled to reference flow.*

**Copper**

*[Technosphere] Copper input, scaled to reference flow.*

**Tracked Output Flows:****PEM, Construction**

*[Reference flow]*

---

**Section II: Process Description**

---

**Associated Documentation**

This unit process is composed of this document and the data sheet (DS) *DS\_C\_PEM\_Electrolysis\_Construction\_2022.01.xlsx*, which provides additional details regarding relevant calculations, data quality, and references.

**Goal and Scope**

This unit process provides a summary of relevant input and output flows associated with the construction of a PEM electrolysis facility in Germany. The facility consists of a PEM stack system and building materials. Functional unit is one construction PEM facility.

**Boundary and Description**

This unit process provides a summary of materials required to construct a PEM electrolysis facility. Operation and maintenance (O&M) is not included within the boundary of this unit process.

Nafion (a polymer material made by DuPont) is the most commonly used proton exchange membrane. Cells are connected electrically in series and hydraulically in parallel to make up a stack. The lifetimes of the stack and the balance of plant were assumed to be 7 and 20 years, respectively, though these can be adjusted as parameters in this profile (Barei et al. 2019).

The material and details were pulled from Barei et al. (2019). The plant construction profile is generic and representative of state-of-the-art low-temperature PEM electrolyzers of the year 2017.

Inputs and outputs have been scaled to a reference flow of 1 piece of PEM, construction.

---

**Figure 1: Unit Process Scope and Boundary**

---

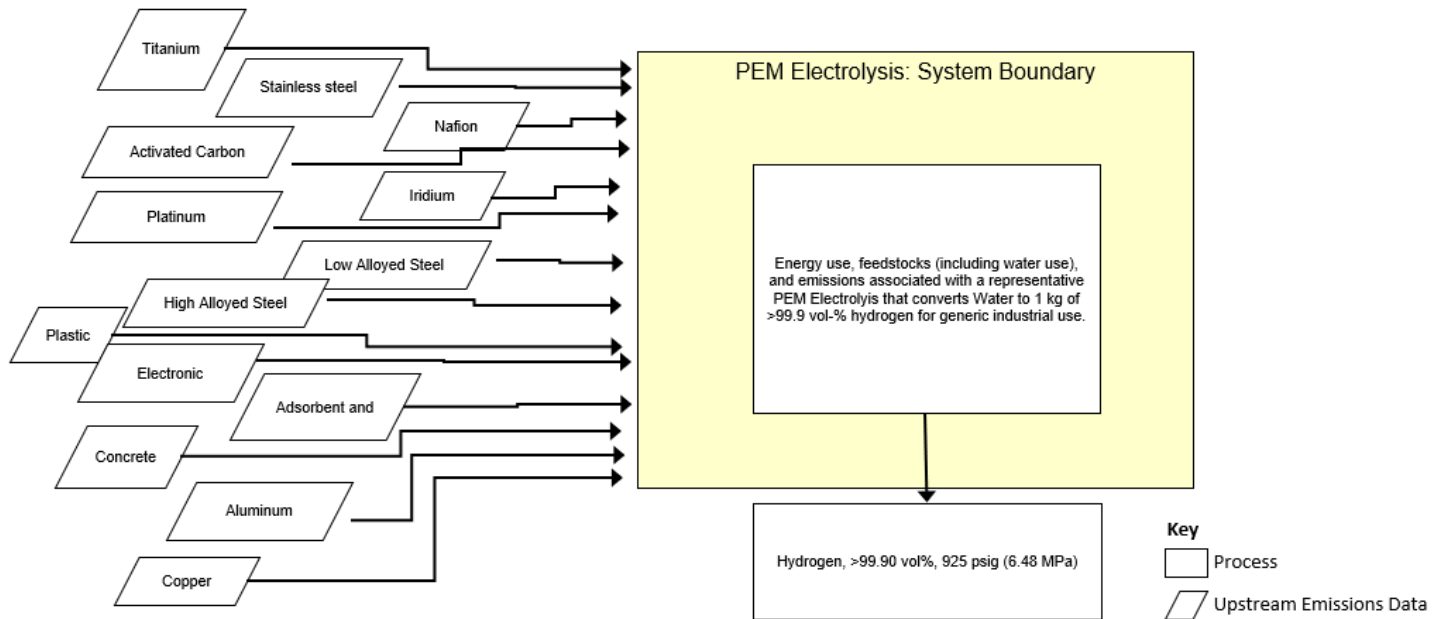

**Table 1: Parameters**

Parameter Name	Expected Value	Low	High	Units	Description
stack_lifetime	7			years	Lifetime of PEM stack.
BOP_lifetime	20			years	Lifetime of PEM balance of plant (BOP).

**Embedded Unit Processes**

None.

**References**

Barei, K., de la Rua, C., Mockl, M., & Hamacher, T. (2019). Life cycle assessment of hydrogen from proton exchange membrane water electrolysis in future energy systems. *Applied Energy*, 237, 862-872.



**Section III: Document Control Information**

---

**Date Created:** August 18, 2022

**Point of Contact:** Timothy Skone (NETL), Timothy.Skone@netl.doe.gov

**Revision History:**

None Yet

**How to Cite This Document:** This document should be cited as:

NETL (2022). NETL Life Cycle Inventory Data – Unit Process: Proton exchange membrane, Construction. U.S. Department of Energy, National Energy Technology Laboratory. Last Updated: August 2022 (version 01). [www.netl.doe.gov/LCA](http://www.netl.doe.gov/LCA) (<http://www.netl.doe.gov/LCA>)

---

**Section IV: Disclaimer**

---

Neither the U.S. Department of Energy (DOE) National Energy Technology Laboratory (NETL) nor any person acting on behalf of these organizations:

- A. Makes any warranty or representation, express or implied, with respect to the accuracy, completeness, or usefulness of the information contained in this document, or that the use of any information, apparatus, method, or process disclosed in this document may not infringe on privately owned rights; or
- B. Assumes any liability with this report as to its use, or damages resulting from the use of any information, apparatus, method, or process disclosed in this document.

Reference herein to any specific commercial product, process, or service by trade name, trademark, manufacturer, or otherwise, does not necessarily constitute or imply its endorsement, recommendation, or favoring by NETL. The views and opinions of the authors expressed herein do not necessarily state or reflect those of NETL.