



New Technology for Trace Contaminant, Acid Gas Removal and Sulfur Recovery from Coal Gasification Syngas

- > Dennis Leppin, P.E., Gas Technology Institute,
Des Plaines, Illinois, USA, Presentor
*Raj Palla, Shain Doong, Rachid Slimane, Howard Meyer, GTI
Scott Lynn, UC-Berkeley, Contributors*

Presented at GTC 2005

San Francisco, CA

October 12, 2005

Disclaimer

- > The work reported in what follows represents research from numerous GTI researchers and subject matter experts and each of the 5 projects discussed can easily be a 20 min talk, so my apologies in advance for any oversimplifications and omissions and general lack of presentation of “data”
- > More detailed presentations are available on most of these topics
- > Contact me if interested
- > Other relevant work is also underway at GTI which was omitted to make for a manageable presentation

Introduction

- > Syngas cleanup is complicated and expensive, but necessary
- > Possibility of advancing the gasifier technology significantly may be moderate at this point
- > GTI is working this issue on several fronts which will be briefly discussed in what follows

Key Issues in Syngas Cleanup

- > Trace contaminant removal
- > Hot Gas Cleanup
- > CO Shift and COS Hydrolysis
- > Bulk S removal
- > High CO₂ to H₂S acid gas treating (selective removal requirement)
- > Low tonnage (<15-20 TPD) S recovery where Claus is not feasible

GTI Technology Developments

- > *UCSRP-HP* Multi-Contaminant Removal
- > *Morphysorb*[®] Process
- > “*Direct Oxidation*” S and Hg Removal/Recovery
- > “*Ultra-Clean*” Process
- > H₂ Membrane Development

Multi-Contaminant Removal Process (UCSRP-HP)

UCSRP-HP Background

- > Developed over a number of years by Scott Lynn, Prof. Emeritus at Univ. of CA, Berkeley. Regents issued lic. option to a private individual, who in turn licensed GTI
- > GTI has conducted technoeconomic studies for natural gas (in which applications a 40% benefit was estimated), bench-scale tests, and recently, tests with syngas
- > DOE, ICCI and GTI now funding scale-up developments at GTI

UCSRP – HP Basic Concept

- > Patented concept
- > Solvent with high temperature stability and high SO₂ and H₂S solubility – DGM and related compounds
- > Homogenous catalyst for Claus Reaction operates above sulfur melting point
- > S combustion to produce SO₂ which is then absorbed in solvent and cycled to absorber – remainder of S removed as product
- > DEG loop to remove other contaminants
- > Syngas delivered at well above S melting point by cross exchanger

Research at GTI - High Pressure Lab Reactor



UCSRP Lab Results

- > Reactions occur with high rates
- > Solvent is stable (40 day test)
- > No unexpected corrosion results
- > Bright sulfur product
- > For syngas application – COS Hydrolysis occurs at reactor conditions

UCSRP Status

- > DOE and ICCI funding further development at GTI
- > GTI tests will include measurement of kinetics and mass transfer and contactor/separation issues and add'l. physical props measurements as well as IGCC reference case (with assistance of ConocoPhillips)

Morphysorb

Project Background

- > Originally started in 1972 to treat coal gasifier effluents under A.G.A contract (1972-77)
- > Screened 108 solvents
- > Selected NFM as the best candidate
- > Project restarted in 1990 under GRI sponsorship and later joined by USDOE
- > Uhde joined GTI team in 1996
- > Laboratory, pilot plant and scale-up studies completed
- > Patented for natural and syngas treating in various regions
- > The process is now commercially available as Morphysorb exclusively through Uhde

Morphysorb Process

> What is it?

- **Proprietary solvent/process**
(GTI and Uhde owns the technology)
- **N- formyl morpholine/
N-acetyl morpholine mixtures**

> What is the application?

- **Bulk or trace removal of acid gas components**
- **Subquality natural gas upgrading to either pipeline or LNG specification**
- **Selective removal of H₂S from natural/synthesis gas for generation of acid gas stream suitable for Claus plant feed**
- **Selective removal of H₂S, CO₂, COS, CS₂, mercaptans and other components from coal/oil gasification syngas at IGCC facilities**

> Advantages

- **Higher solvent loading = lower circulation or higher throughput**
- **Lower co-absorption of hydrocarbons (less losses)**
- **Low corrosion, low environmental hazard**
- **Low foaming potential**
- **Low capital and operating costs**

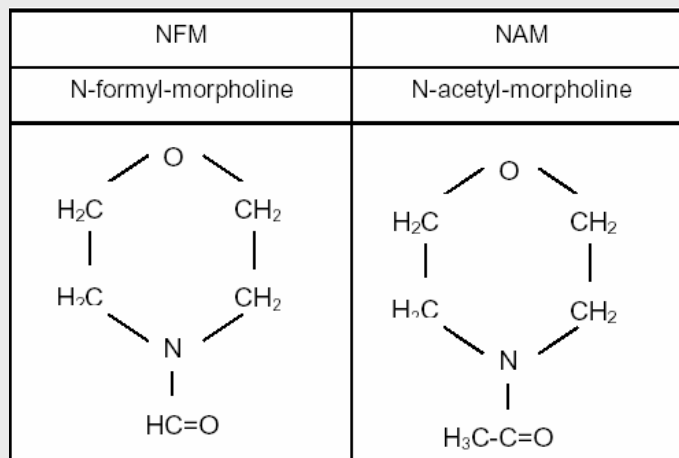

Morphysorb Pilot Plant Test Unit

Pilot Plant Specifications

- Pressure, 1200 psig
- Circulation Rate, 35 gpm max.
- Feed Gas Flow Rates Up to 1.2 MMSCF/d
- Overall Dimensions, 12 x 12 x 60 ft.
- To be relocated to FlexFuel in 2005



Planned Mods to Flex-Fuel Facility

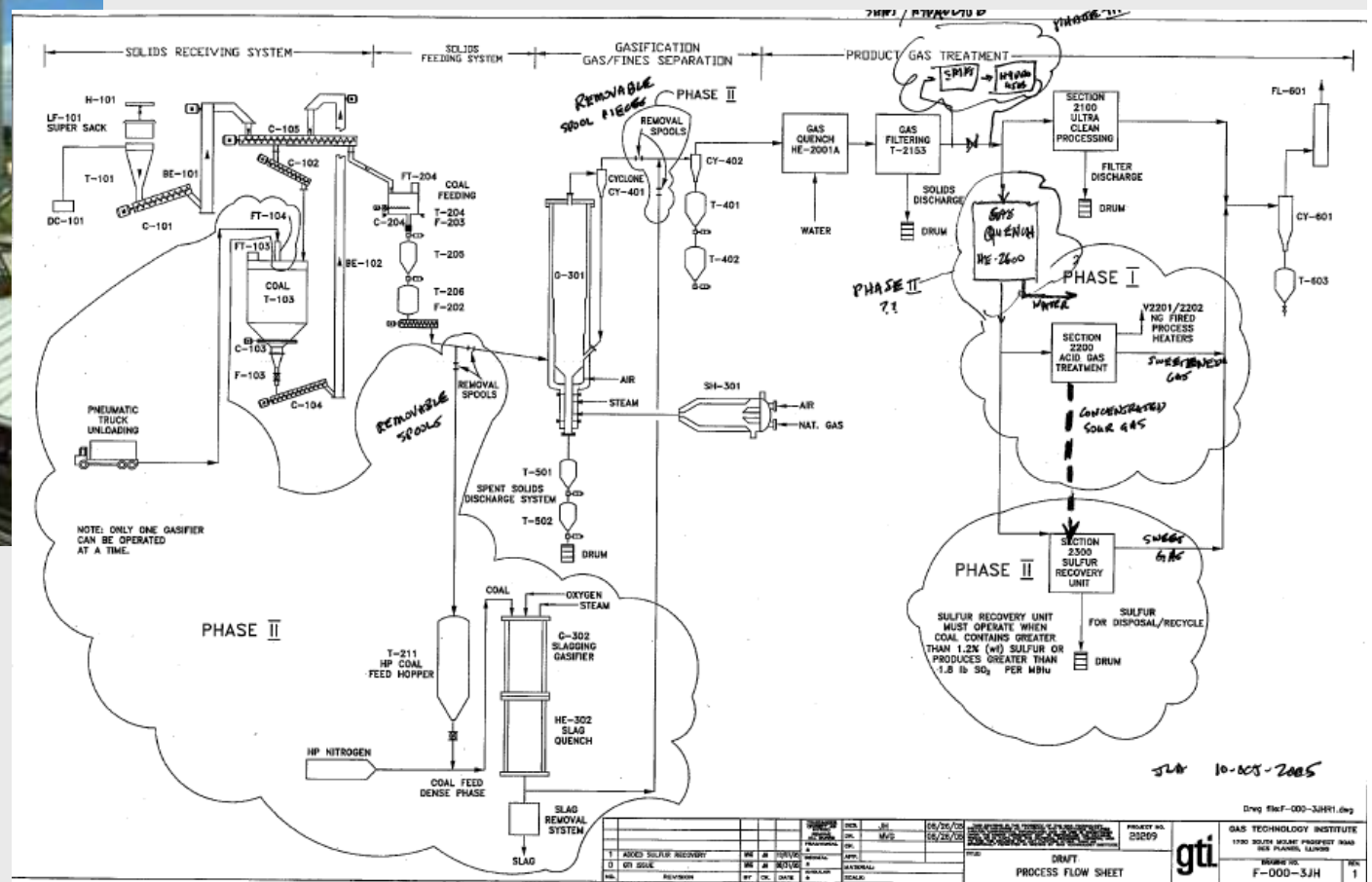

Duke Energy's Kwoen Plant World's Largest AGI Facility



Kwoen Plant Process Flow Diagram

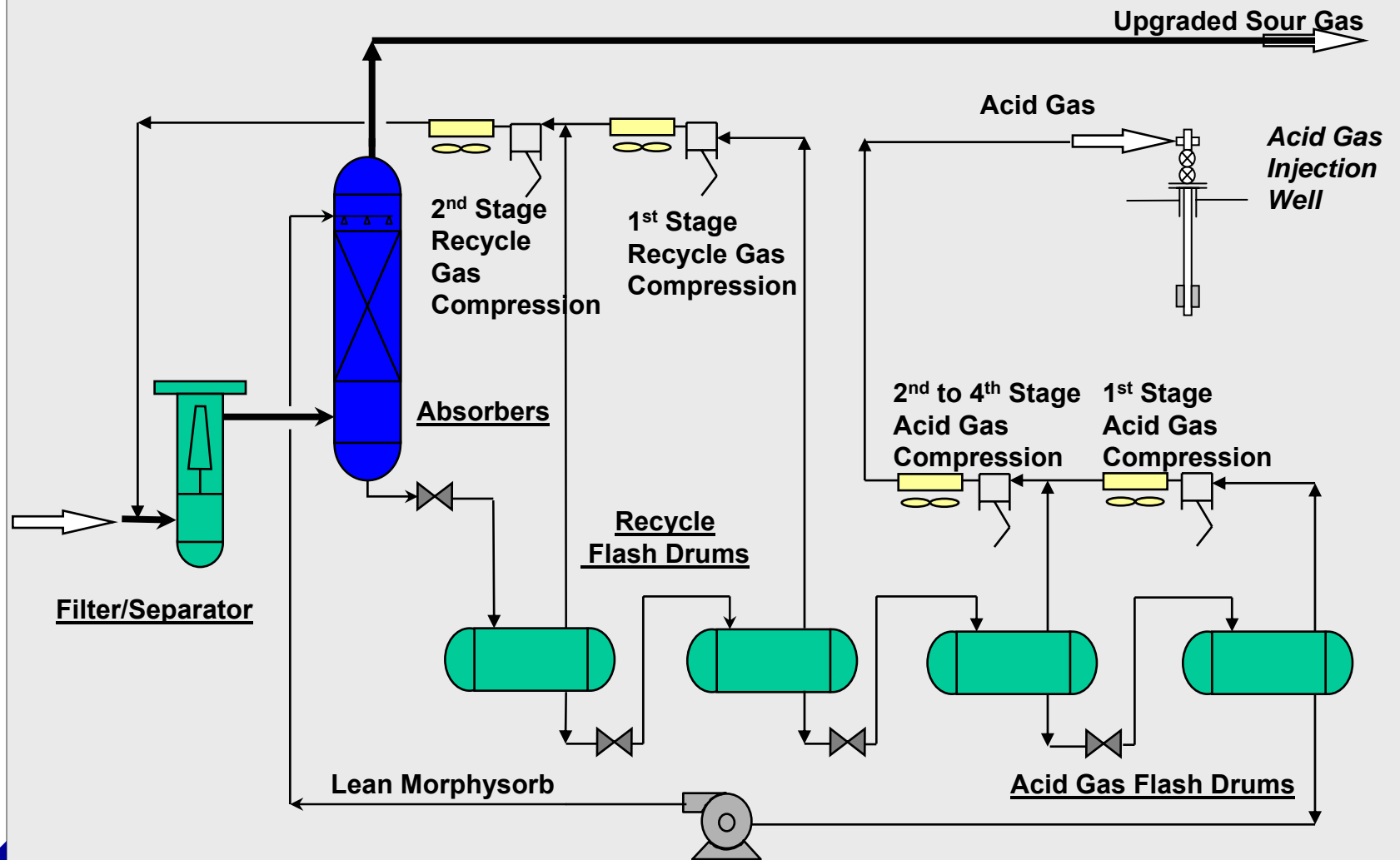

First Commercial Application Brief Highlights—

Duke Energy's Kwoen Gas Plant (as of 2Q'05)

- > The process is operating successfully without any solvent-related problems
- > Processed over 200 Bcf of sour gas
- > ~17 Bcf of Acid Gas Injected (~30 MMSCFD)
- > Exceeded performance targets set forth in the demonstration agreement
- > No corrosion related issues
- > Recent process modifications for high CO₂ removal are successful
 - Acid Gas Stream Composition (Prior to the changes)
 - > 85% H₂S, 14% CO₂ and 1% CH₄
 - Acid Gas Stream Composition (After process modifications)
 - > 67% H₂S, 30% CO₂ and >2.5 % CH₄

Research Issues for Morphysorb Use for Syngas Treating

- > Define target specifications
- > Performance Data
 - Loading, Flash Gas rate, pickup H₂S vs. CO₂, partitioning of trace contaminants, optimum temperature, flash pressures, regen. conditions
- > COS Hydrolysis – further quantification needed
- > Experience needed with heated and/or vacuum regeneration
- > Obtain solvent degradation data
- > VLE data (K-values) on specific components of interest (we have some but may not be at correct conditions)
- > Piloting and Demonstration

Morphysorb Summary

- > Commercial for Bulk Acid Gas Removal
 - Several add'l. world-scale plants in various licensing stages
- > Can be configured for various treating services, e.g., pure CO₂ capture, LNG feed specs (50 ppmv CO₂), natural gas treating (4 ppmv H₂S) and syngas cleanup
- > May have advantageous properties for syngas treating? Higher capacity?, COS hydrolysis, lower H₂ absorption, lower eq'd. circ. Rates
- > Further testing for syngas is warranted – not currently funded but some in-house research being carried out by Uhde GmbH and GTI.

Direct Oxidation of H₂S

“DO” Concept



- Limits to amount of H₂S that can be processed in a single-stage
- Equilibrium conversion limits
- Hg may be removed concomitantly along with elemental S
- Various “Back-End” processes may be envisioned
- Offered Commercially by M-I SulfaTreat for Natural Gas cleanup

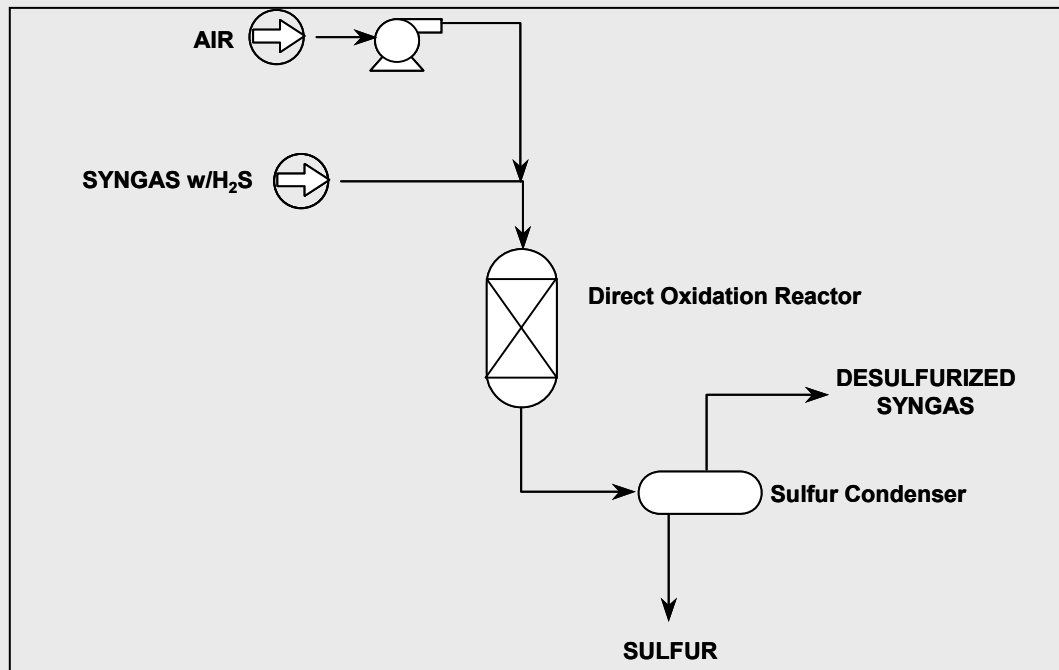

CTU for High Pressure Operation

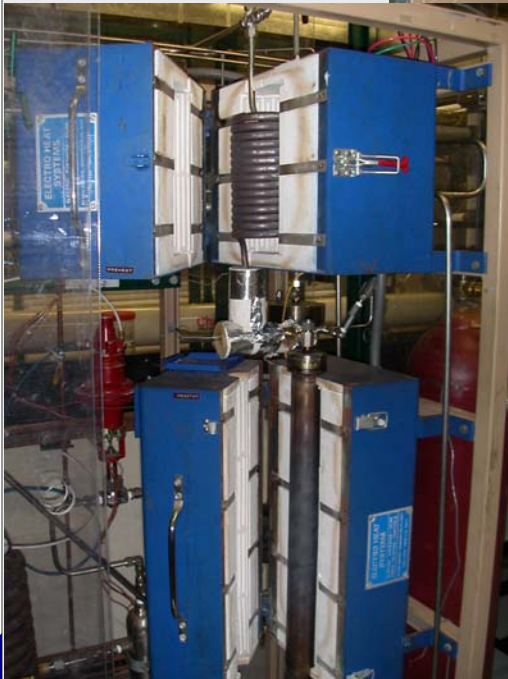

- > CTU is rated for 800 psig operation
- > Simulated gas blended via seven mass flow controllers
- > CTU can be operated up to 700 °F
- > Equipped with State-of-the-art Analytical Systems
- > Ambient Personal Monitors
 - H₂S, SO₂, LEL and CO

CTU Simplified PFD

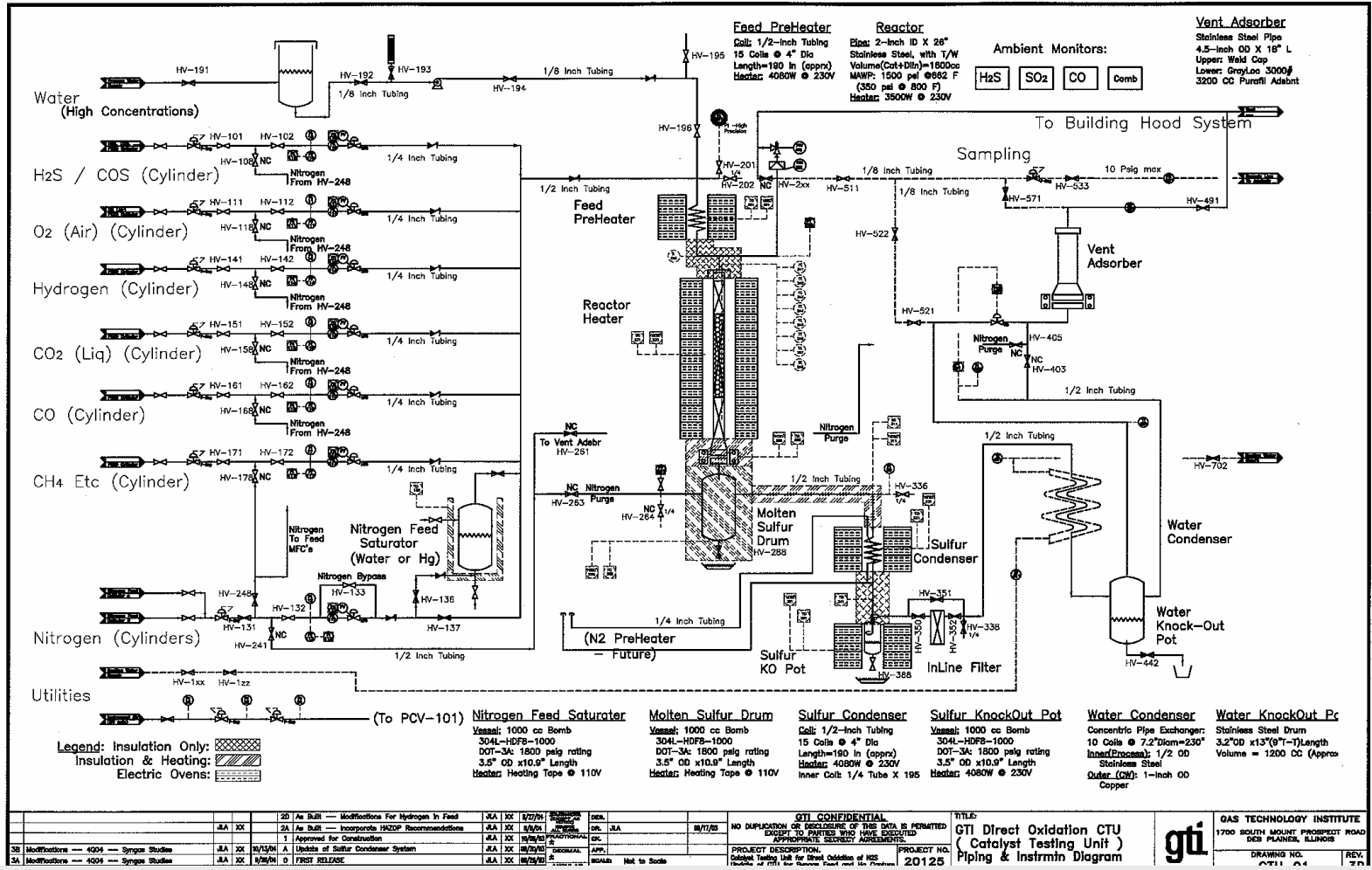

DO Research Status

- > Increasing the oxygen:hydrogen sulfide ratio above the stoichiometric level of 0.5 (for the reaction of hydrogen sulfide to elemental sulfur) does improve the conversion of hydrogen sulfide and the yield of elemental sulfur, without causing significant undesirable reactions of oxygen. The conversion rates are in the range of 58 to 69%.
- > The benefits of increased oxygen in the feed diminish, as the $O_2:H_2S$ ratio is increased beyond about 0.75.
- > Very little oxidation of either carbon monoxide or hydrogen (the valuable components of the syngas) was apparent in any of the test conditions of the experiments; most of the oxygen consumed in the feed could be accounted for by the direct oxidation of the feed hydrogen sulfide.
- > Very little oxidation of either carbon monoxide or hydrogen (the valuable components of the syngas) was apparent in any of the test conditions of these experiments. In these experiments, although the primary product of the direct oxidation of hydrogen sulfide was elemental sulfur, there was some amount of carbonyl sulfide formed.

Ultra-Clean Process

Novel Gas Cleaning Process

Concept: Use an existing **particulate control device** (barrier filter) as a **chemical reactor** for multi-pollutant control at hot/warm temperatures

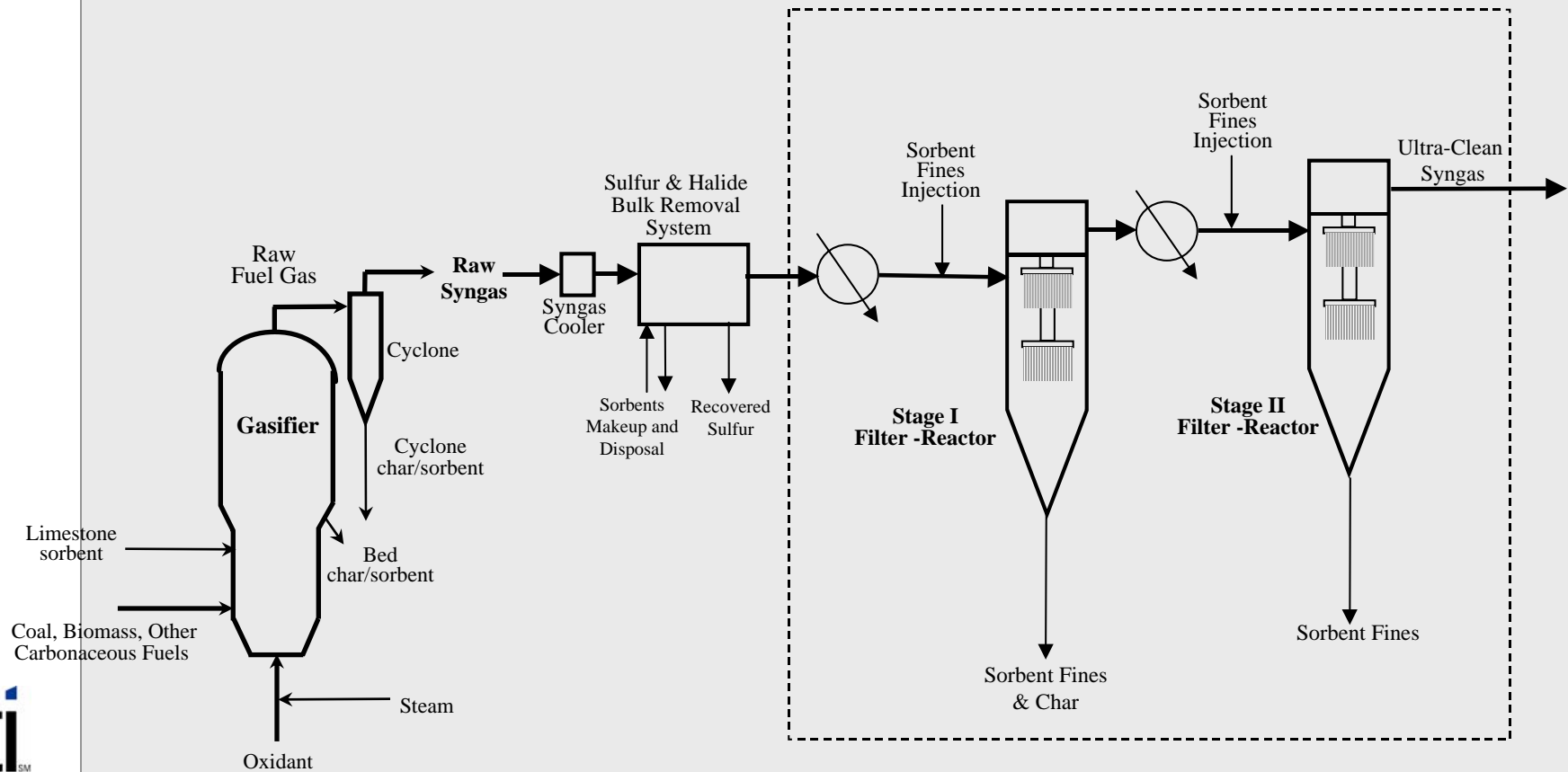

PCD's as Barrier Filter-Reactors

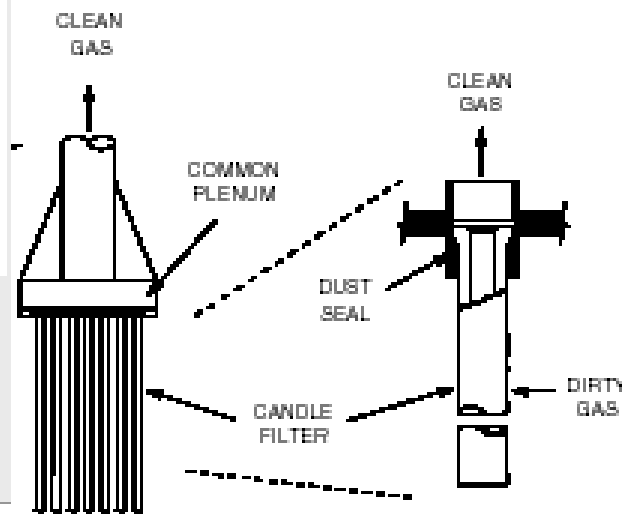
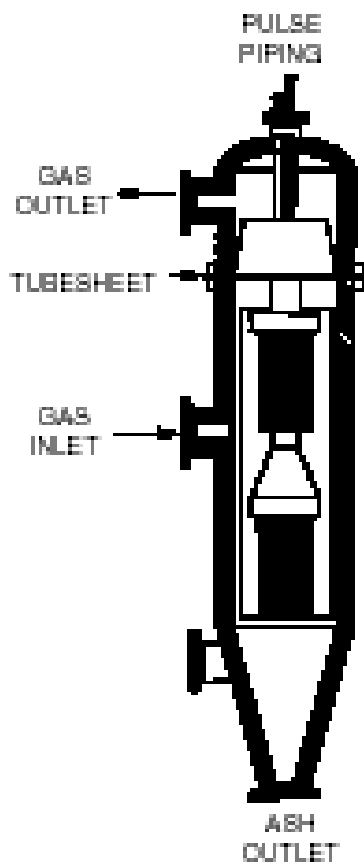

➤ Barrier filters applied as semi-continuous packed-bed reactors for simultaneous control of particulates and gaseous contaminants

- Dry Process
- Avoids fuel gas condensation

➤ Coupling efficient particle capture with an effective entrained/filter cake reaction environment

➤ Multiple contaminants can be simultaneously controlled in a single filter-reactor vessel (S, halide, and Hg compounds)

➤ Potential to incorporate capability to control other contaminants (ammonia, trace metals (As, Se, Cd))

➤ Process uses powdered sorbent particles with very high specific surface area

- No need for highly porous support structure
- No need for special particle attrition resistance

↓
Low-cost

Pilot Test Facility Configuration

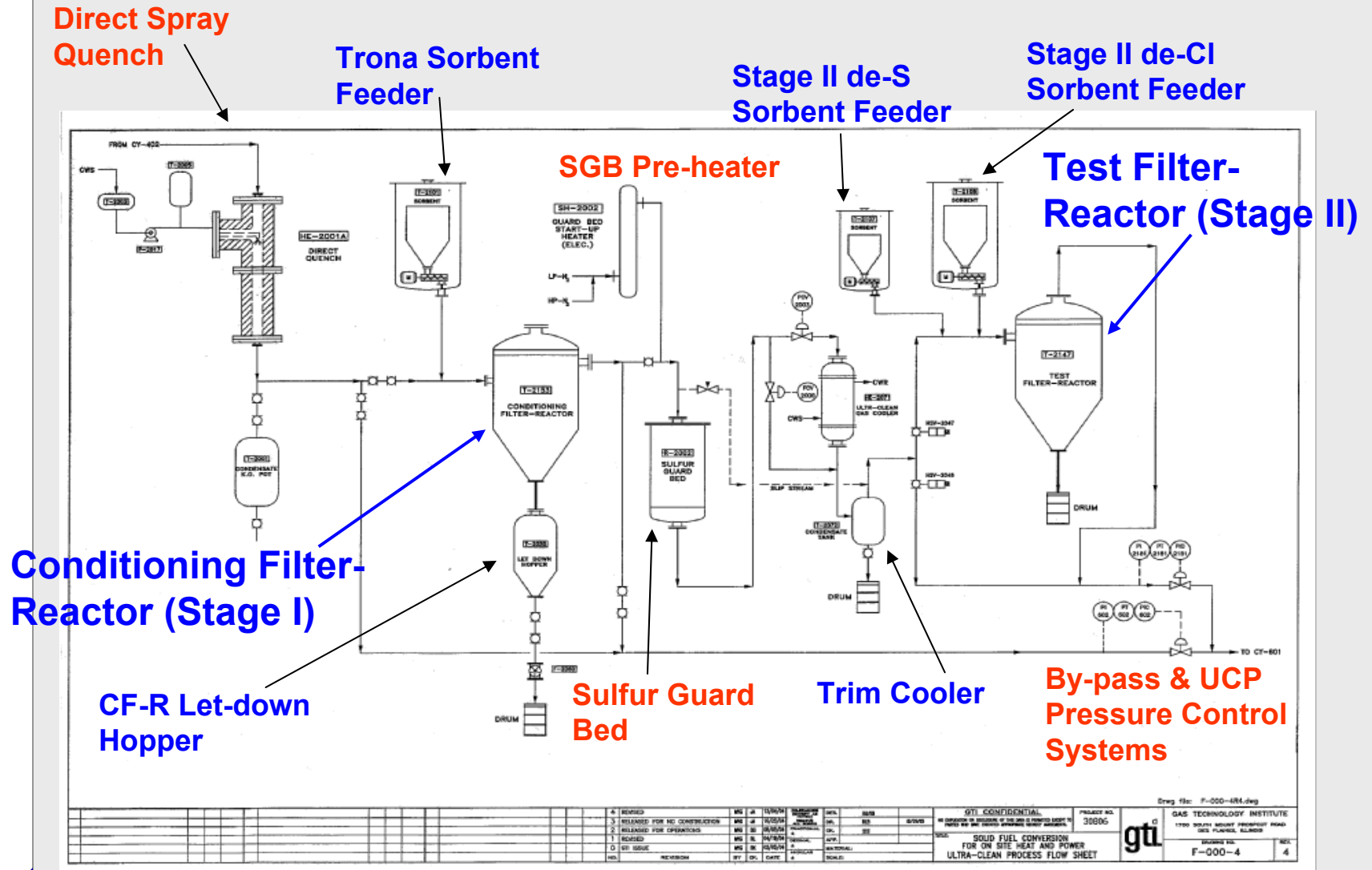

Sorbent Injection Systems

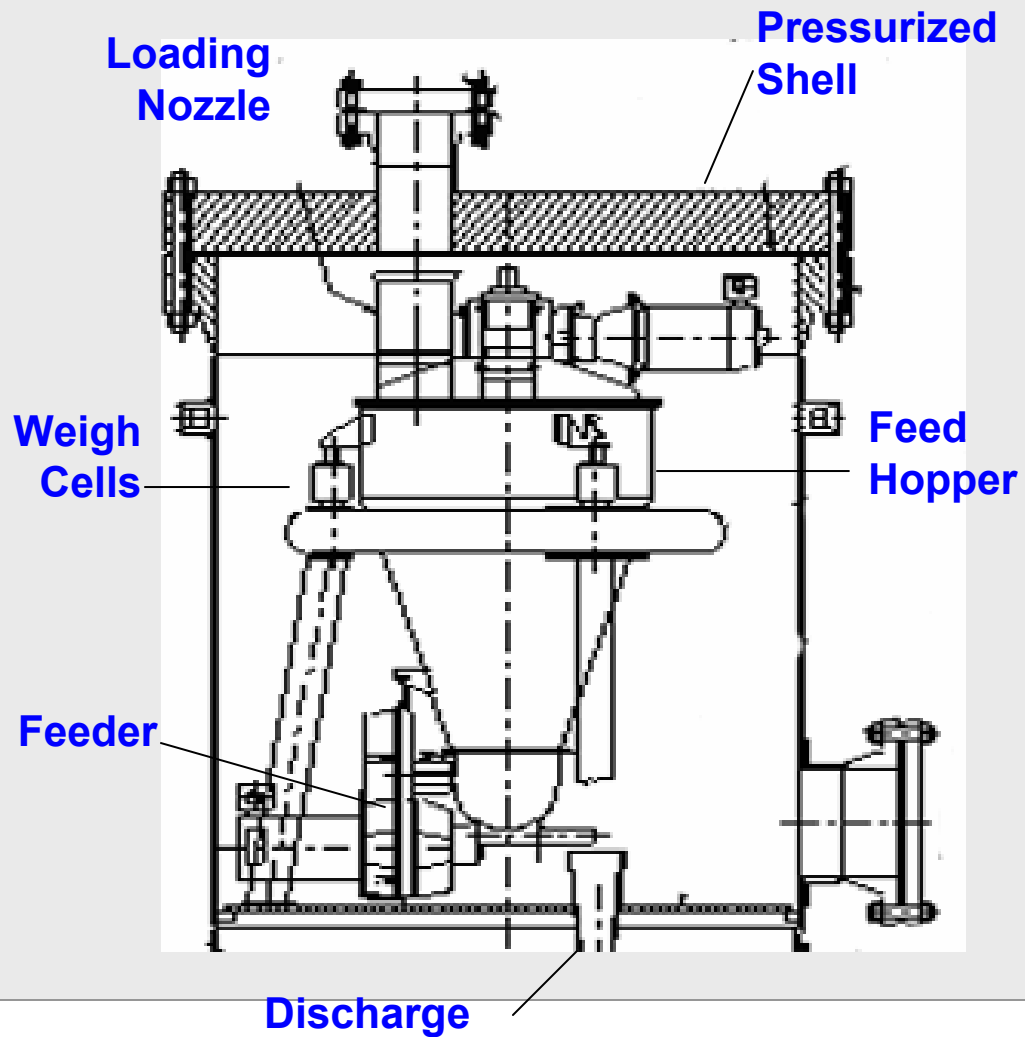

Stage II de-S & de-Cl Sorbent Feed Systems

Pilot Test Facility Configuration Showing Sampling Points for Solids, Liquids, and Gases

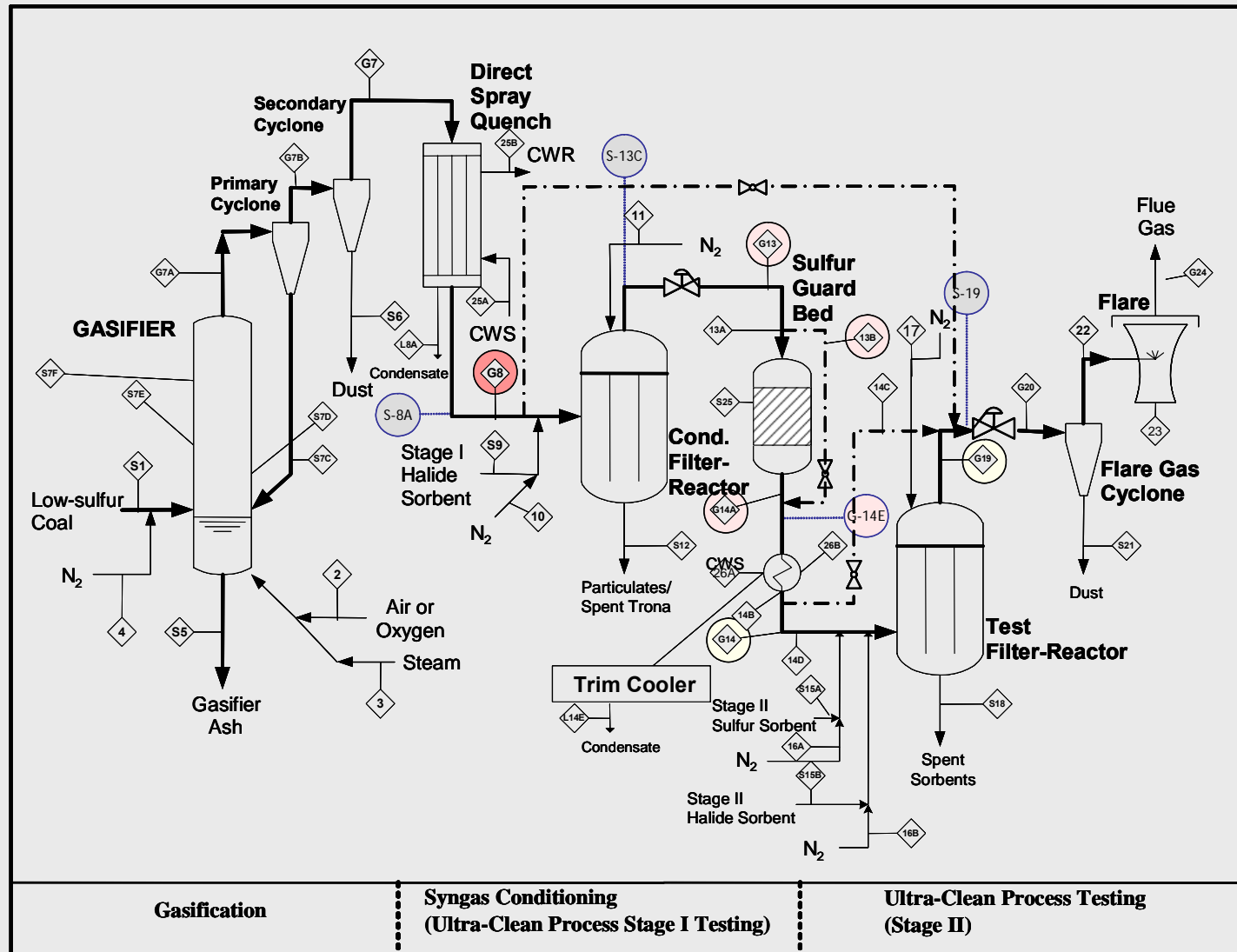

Analytical Equipment for Ultra-Clean Testing



H₂ Membrane Process

H₂ Membrane Concept

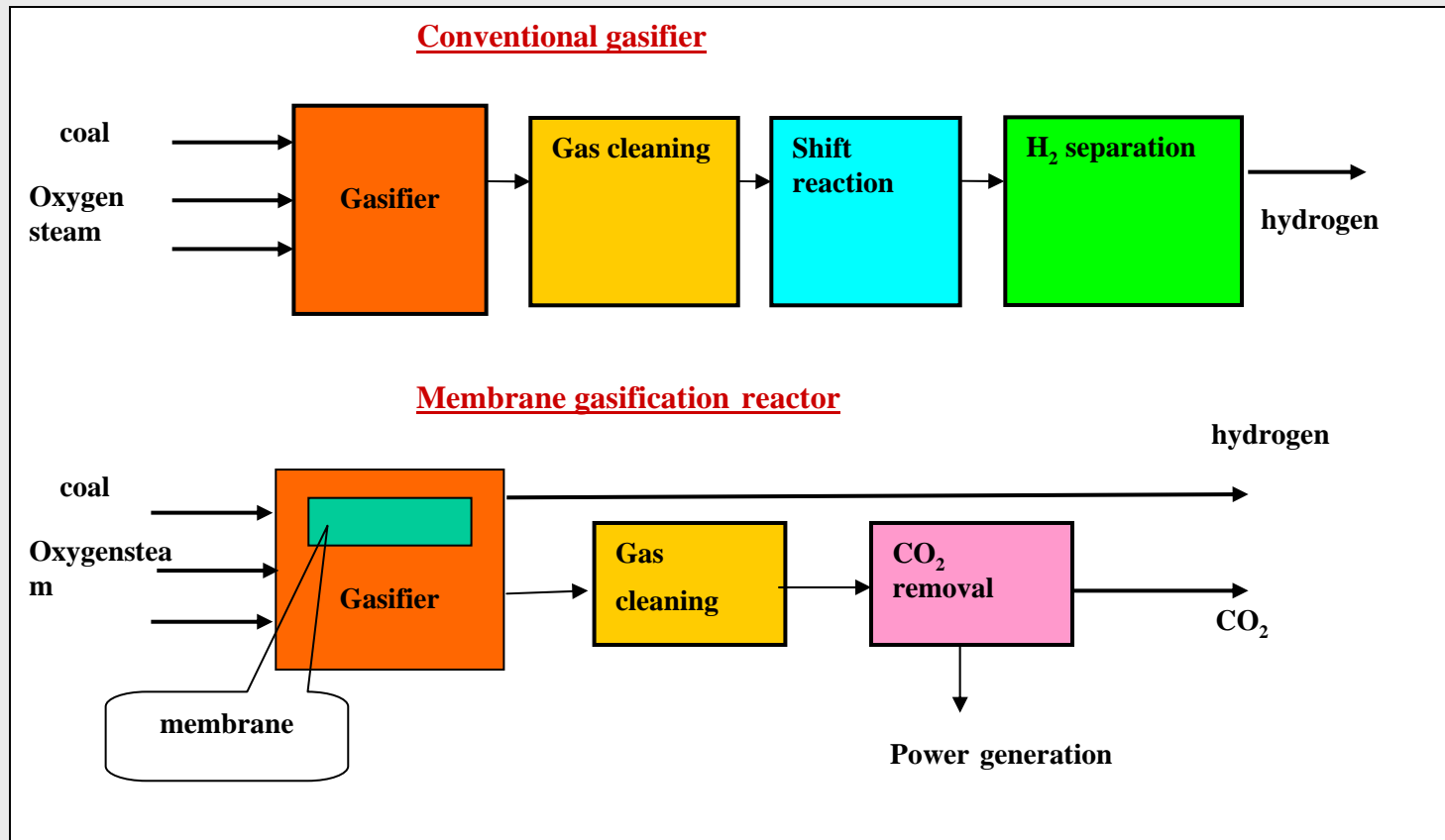

GTI High Temperature/High Pressure Permeation Unit

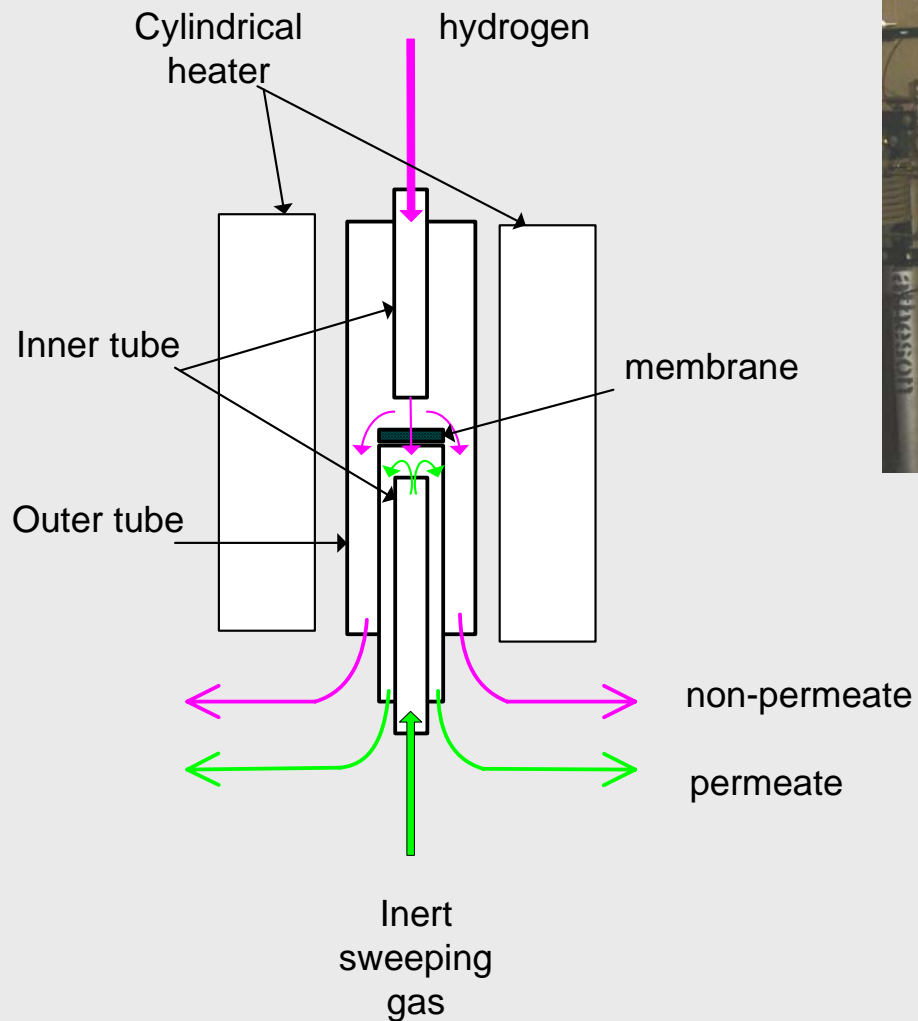

Potential Benefits of Membrane Reactor for Hydrogen Production from Coal

> **High H₂ production efficiency:**

- Thermodynamic analysis and recent modeling work indicate over 30 - 50% improvement in H₂ production efficiency over the current gasification technologies

> **Low cost:**

- reduce/eliminate downstream processing steps

> **Clean product:**

- no further conditioning needed, pure hydrogen

> **CO₂ sequestration ready:**

- simplify CO₂ capture process

> **Power co-generation:**

- utilization of non-permeable coal syngas

Proton-Conducting Membranes Identified as Leading Candidate Materials

> Perovskite membranes evaluated:

- $\text{BaCe}_{0.9}\text{Nd}_{0.1}\text{O}_{3-\alpha}$ (BCN) (supported or unsupported)
- $\text{BaCe}_{0.8}\text{Y}_{0.2}\text{O}_{3-\alpha}$ (BCY)
- $\text{SrCe}_{1-x}\text{Eu}_x\text{O}_{3-\alpha}$ (SCE)
- $\text{SrCe}_{0.95}\text{Tm}_{0.05}\text{O}_{3-\alpha}$ (SCTm)

Membrane Fabrication

- > Die pressing or tape casting for self supporting membranes
- > Supported membrane: same material for both porous and dense layers

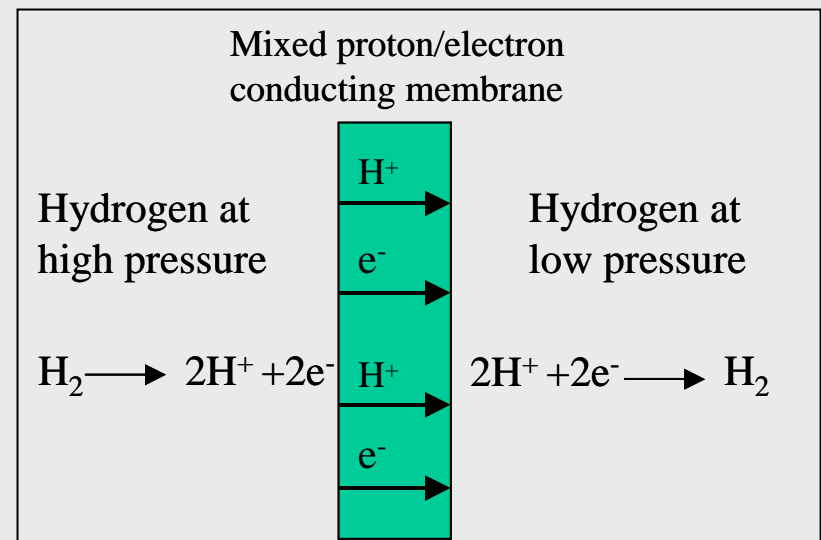

Some Experimental Results

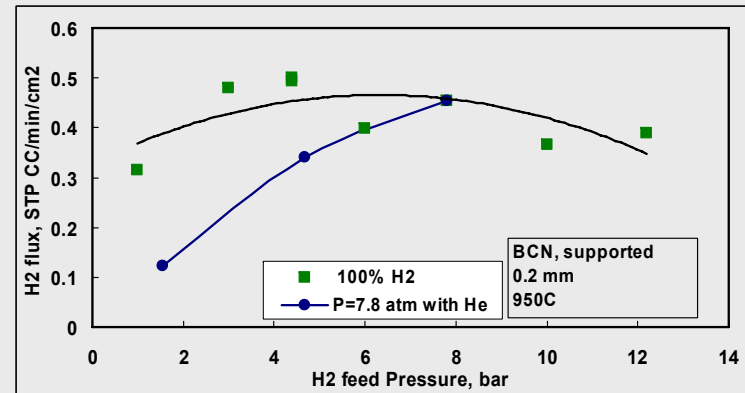
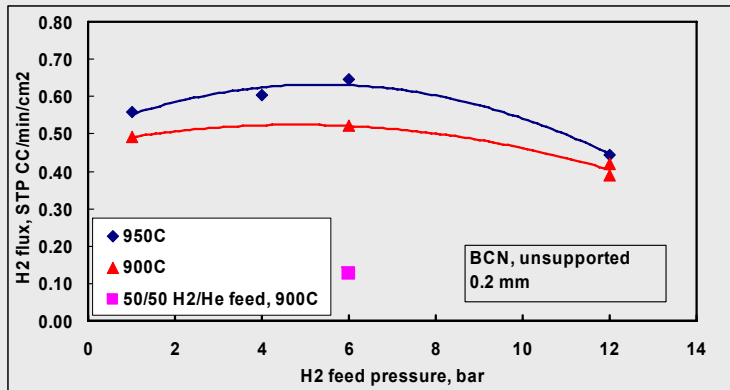

H₂ Flux for BCN membranes

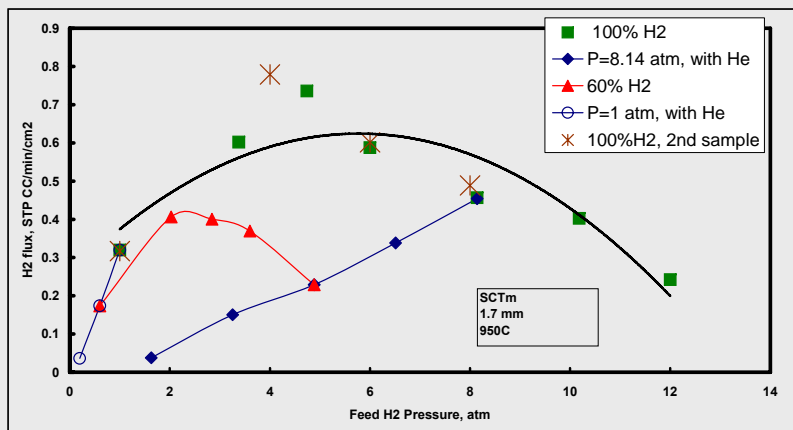

H₂ Flux for SCTm membranes

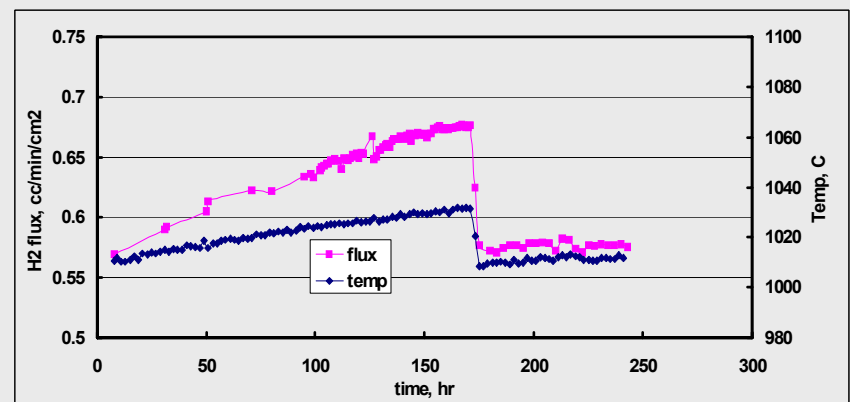

Stability Testing (pure H₂)

H₂ Membrane Status

- > Several barium/strontium cerate-based perovskite membranes show reasonable hydrogen flux at gasification temperatures
- > Hydrogen flux increases with pressure (to about 4 bar) and temperature
- > Conceptual design showed that a membrane module could be configured within a fluidized bed gasifier without a substantial increase of the gasifier dimensions
- > Identified Zr-doped perovskite membranes as potential materials for further testing with respect to the chemical stability issues in the coal-derived syngas environment

CONCLUSIONS

- > A robust R&D program is underway with gov't. and industry sponsorship – many difficult and challenging issues need to be addressed
- > Several key issues of syngas cleanup are being addressed
- > Significant cost reductions in a variety of applications are possible
- > GTI has developed flexible facilities for conduct of syngas-related research
- > Stay tuned for developments and your participation in licensing, utilization of results, offering host sites, or other financial participation would be most welcome

For Detailed Further Information

- > Contact Vann Bush or Dennis Leppin at GTI

Vann.Bush@gastechnology.org

Dennis.Leppin@gastechnology.org

Thank You

- > For staying around for the last paper and please have a safe journey home